

WELCOME

The vehicle presents you a challenge to master the machine, a challenge to adventure. You ride through the wind, linked to the road by a vehicle that responds to your commands as no other does. Unlike an automobile, there is no metal cage around you. Like an air plane, a pre-ride inspection and regular maintenance are essential to your safety. Your reward is freedom.

To meet the challenges safely, and to enjoy the adventure fully, you should become thoroughly familiar with this owner's manual BEFORE YOU RIDE THE VEHICLE.

As you read this manual, you will find information that is preceded by a **NOTICE** symbol. This information is intended to help you avoid damage to your vehicle, other property, or the environment.

When service is required, remember that your Honda dealer knows your vehicle. If you have the required mechanical "know-how" and tools, your dealer can supply you an official Honda shop manual on paid basis to help you perform many maintenance and repair tasks.

Accessories shown in the illustration are not part of the standard equipment.

For any query or assistance, please call Customer Care No.:

1800 103 3434 (Toll free)

Pleasant riding, and thank you for choosing a Honda!

- The specifications may vary with each locale.

© Honda Motor Co., Ltd. 2017

Honda Motorcycle & Scooter India Pvt. Ltd.

CB125 Shine SP

IMPORTANT INFORMATION

- **RIDER AND PILLION RIDER**

This vehicle is designed to carry the rider and one pillion rider. Never exceed the maximum weight capacity.

- **ON-ROAD USE**

This vehicle is designed to be used only on the road.

- **READ THIS OWNER'S MANUAL CAREFULLY**

Pay special attention to the safety messages that appear throughout the manual.

This manual should be considered as a permanent part of the vehicle and should remain with the vehicle when resold.

All information in this publication is based on the latest production information available at the time of approval for printing. Honda Motor Co., Ltd. reserves the right to make changes at any time without notice and without incurring any obligation.

No part of this publication may be reproduced without written permission.

TABLE OF CONTENTS

	Page		Page
CATALYTIC CONVERTER -----	1	Fuel -----	19
A FEW WORDS ABOUT SAFETY -----	2	Evaporative Emission Control System --	21
VEHICLE SAFETY -----	3	Engine Oil -----	22
Important Safety Information-----	3	Tyres-----	23
Protective Apparel -----	4	ESSENTIAL INDIVIDUAL	
Load Limits and Guidelines-----	5	COMPONENTS -----	26
Anti-theft Tips-----	7	Ignition Switch -----	26
PARTS LOCATION -----	8	Right Handlebar Control -----	27
Serial Numbers-----	10	Left Handlebar Controls -----	27
Instrument and Indicators -----	10	FEATURES -----	28
MAJOR COMPONENTS -----	12	(Not required for operation)	
(Information you need to operate this		Steering Lock -----	28
vehicle)		Headlight Aim Vertical Adjustment -----	29
Suspension -----	12	Left Side Cover-----	29
Brakes -----	13	Seat-----	30
Clutch-----	18	Storage Compartment-----	31
		Document Bag -----	31

TABLE OF CONTENTS

	Page		Page
OPERATION -----	32	Throttle Operation -----	50
Pre-ride Inspection -----	32	Air Cleaner -----	51
Starting the Engine -----	32	Drive Chain-----	52
Running-in -----	35	Front and Rear Suspension-----	57
Riding-----	35	Side Stand -----	58
Braking -----	36	Wheel Removal-----	58
Parking -----	37	Brake Pad Wear (for Disc & CBS) -----	62
MAINTENANCE -----	38	Brake Shoe Wear -----	63
The Importance of Maintenance -----	38	Battery -----	64
Maintenance Safety -----	38	Fuse Replacement -----	66
Safety Precautions -----	39	Stoplight Switch Adjustment -----	68
Maintenance Schedule-----	40	Bulb Replacement-----	68
Tool Kit and First Aid Kit-----	43	CLEANING -----	71
Color Code -----	43	STORAGE GUIDE -----	73
Engine Oil -----	44	Storage -----	73
Crankcase Breather-----	46	Removal From Storage -----	74
Spark Plug-----	46	SPECIFICATIONS -----	75
Valve Clearance -----	48	WARRANTY POLICY -----	77
Idle Speed-----	50		

CATALYTIC CONVERTER

This Vehicle is equipped with a catalytic converter.

The catalytic converter contains precious metals that serve as catalysts. Promoting chemical reactions to convert the exhaust gasses without affecting the metals.

The catalytic converter acts on HC, CO, and NOx. A replacement unit must be an original Honda part or its equivalent.

The catalytic converter must operate at a high temperature for the chemical reactions to take place. It can set on fire any combustible materials that come near it. Mark your vehicle away from high grasses, dry leaves, or other flammables.

A defective catalytic converter contributes to air pollution, and can impair your engine's performance. Follow these guidelines to protect your motorcycle's catalytic converter.

- Always use unleaded petrol. Even a small amount of leaded petrol can contaminate the catalyst metals, making the catalytic converter ineffective.
- Keep the engine tuned-up.
- Have your vehicle diagnosed and replaced if it is misfiring, backfiring stalling or otherwise not running properly.

A FEW WORDS ABOUT SAFETY

Your safety, and the safety of others, is very important. Operating this vehicle safely is an important responsibility.

To help you make informed decisions about safety, we have provided operating procedures and other information on labels in this manual. This information alerts you to potential hazards that could hurt you or others.

Of course, it is not practical or possible to warn you about all hazards associated with operating or maintaining a vehicle. You must use your own good judgment.

You will find important safety information in a variety of forms, including :

- **Safety labels** - on the vehicle.
- **Safety messages** - preceded by a safety alert symbol  and one of three signal words: **DANGER**, **WARNING**, or **CAUTION**.

These signal words mean:

 **DANGER** You **WILL** be **KILLED** or **SERIOUSLY HURT** if you don't follow instructions.

 **WARNING** You **CAN** be **KILLED** or **SERIOUSLY HURT** if you don't follow instructions.

 **CAUTION** You **CAN** be **HURT** if you don't follow instructions.

- **Safety Heading** - such as Important Safety Reminders or Important Safety Precautions.
- **Safety Section** – such as vehicle Safety.
- **Instructions** – how to use this vehicle correctly and safely.

This entire manual is filled with important safety information—please read it carefully.

VEHICLE SAFETY

IMPORTANT SAFETY INFORMATION

Your vehicle can provide many years of service and pleasure if you take responsibility for your own safety and understand the challenges that you can meet on the road.

There is much that you can do to protect yourself when you ride. You'll find many helpful recommendations throughout this manual. Following are few that we consider most important.

Always Wear a Helmet

It's a proven fact: helmets significantly reduce the number and severity of head injuries. So always wear an approved helmet and make sure your pillion rider does the same. We also recommend that you wear eye protection, sturdy boots, gloves, and other protective apparel (page 4).

Make Yourself Easy to be Visible

Some drivers do not see vehicles because they are not looking for them. To make yourself more visible, wear bright reflective clothing, position yourself so other drivers can see you, signal before turning or changing lanes, and use your horn when it will help others notice you.

Ride Within Your Limits

Pushing the limits is another major cause of vehicle accidents. Never ride beyond your personal abilities or faster than conditions warrant. Remember that alcohol, drugs, fatigue and inattention can significantly reduce your ability to make good judgements and ride safely.

Keep Your Vehicle in Safe Condition

For safe riding, it's important to inspect your vehicle before every ride and perform all recommended maintenance. Never exceed load limits, and only use accessories that have been approved by Honda for this vehicle. See page 6 for more details.

Don't Drink and Ride

Don't mix Alcohol and riding. Even one drink can reduce your ability to respond to changing conditions, and your reaction time gets worse with every additional drink. So don't drink and ride, and don't let your friends drink and ride either.

PROTECTIVE APPAREL

For your safety, we strongly recommend that you always wear an approved helmet, eye protection, boots, gloves, long pants, and a long-sleeved shirt or jacket whenever you ride. Although complete protection is not possible, wearing proper gear can reduce the chance of injury when you ride. Following are suggestions to help you choose proper gear.

WARNING

Not wearing a helmet increases the chance of serious injury or death in a crash.

Be sure you and your pillion rider always wear a helmet, eye protection and other protective apparel when you ride.

Helmets and Eye Protection

Your helmet is your most important piece of riding gear because it offers the best protection against head injuries. A helmet should fit your head comfortably and securely. A bright-colored helmet can make you more noticeable in traffic, as can reflective strips.

An open-face helmet offers some protection, but a full-face helmet offers more. Always wear a face shield or goggles to protect your eyes and help your vision.

Additional Riding Gear

In addition to a helmet and eye protection, we also recommend:

- Sturdy boots with non-slip soles to help protect your feet and ankles.
- Leather gloves to keep your hands warm and help prevent blisters, cuts, burns and bruises.
- A vehicle riding suit or jacket for comfort as well as protection. Bright colored and reflective clothing can help make you more noticeable in traffic. Be sure to avoid loose clothes that could get caught on any part of your vehicle.

LOAD LIMITS AND GUIDELINES

Your vehicle has been designed to carry you and one pillion rider. When you carry a pillion rider, you may feel some difference during acceleration and braking. But so long as you keep your vehicle well-maintained, with good tyres and brakes, you can safely carry loads within the given limits and guidelines.

However, exceeding the weight limit or carrying an unbalanced load can seriously affect your vehicle's handling, braking and stability. Non-Honda accessories, improper modifications, and poor maintenance can also reduce your safety margin.

The following pages give more specific information on loading, accessories and modifications.

Loading

How much weight you put on your vehicle, and how you load it, are important to your safety. Anytime you ride with a pillion rider or cargo you should be aware of the following information.

WARNING

Overloading or improper loading can cause a crash and you can be seriously hurt or killed.

Follow all load limits and other loading guidelines in this manual.

Load Limits

Following are the load limits for your vehicle:

Maximum weight capacity:

170 kg (374.7 lbs)

Includes the weight of the rider, pillion rider, all cargo and all accessories

Loading Guidelines

Your vehicle is primarily intended for transporting you and a pillion rider. You may wish to secure a jacket or other small items to the seat when you are not riding with a pillion rider. If you wish to carry more cargo, check with your Honda dealer for advice, and be sure to read the information regarding accessories on (page 6).

Improperly loading your vehicle can affect its stability and handling. Even if your vehicle is properly loaded, you should ride at reduced speeds whenever carrying cargo. Follow these guidelines whenever you carry a pillion rider or cargo:

- Check that both tyres are properly inflated.
- If you change your normal load, you may need to adjust the rear suspension (page 12).
- To prevent loose items from creating a hazard, make sure that all cargo is securely tied down before you ride away.
- Place cargo weight as close to the center of the vehicle as possible.
- Balance cargo weight evenly on both sides.
- Do not attach large or heavy items (such as a sleeping bag or tent) to the handlebars, forks or fender.

Accessories and Modifications

Modifying your vehicle or using non-Honda accessories can make your vehicle unsafe. Before you consider making any modifications or adding an accessory, be sure to read the following information.

WARNING

Improper accessories or modifications can cause a crash in which you can be seriously hurt or killed.

Follow all instructions in this owner's manual regarding accessories and modifications.

Accessories

We strongly recommend that you use only Honda Genuine Accessories that have been specifically designed and tested for your vehicle. Because Honda cannot test all other accessories, you must be personally responsible for proper selection, installation and use of non-Honda accessories. Check with your dealer for assistance and always follow these guidelines:

- Make sure the accessory does not obscure any lights, reduce ground clearance and banking angle, limit suspension travel or steering travel, alter your riding position or interfere with operating any controls.

- Be sure not to use any non-genuine electrical equipment or equipment having capacity exceeding vehicle's electrical system capacity (page 76). A blown fuse can cause a loss of lights or engine power.
- Do not pull a trailer or sidecar with your vehicle. This vehicle is not designed for these attachments, and their use can seriously impair your vehicle's handling.

Modification

We strongly advise you not to remove any original equipment or modify your vehicle in any way that would change its design or operation. Such changes could seriously impair your vehicle's handling, stability and braking, making it unsafe to ride.

Removing or modifying your lights, mufflers, emission control system or other equipment can also make your vehicle illegal.

ANTI-THEFT TIPS

1. Always lock the steering.
2. Never leave the key in the ignition switch. This sounds simple but people do forget.
3. Be sure the registration information for your vehicle is accurate and current.
4. Put your vehicle in a locked garage whenever possible.
5. Use an additional anti-theft device of good quality.
6. Put your name, address, and phone number in this Owner's Manual and keep it on your vehicles at all times. Many times stolen vehicles are identified by information in the Owner's Manuals.

NAME: _____

ADDRESS: _____

PHONE NO: _____

PARTS LOCATION

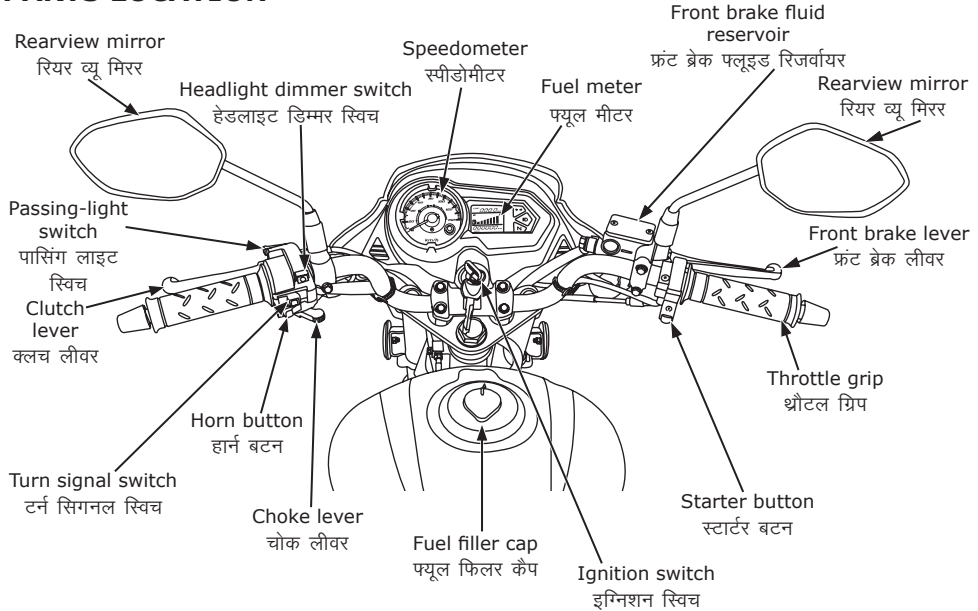

Right Side View

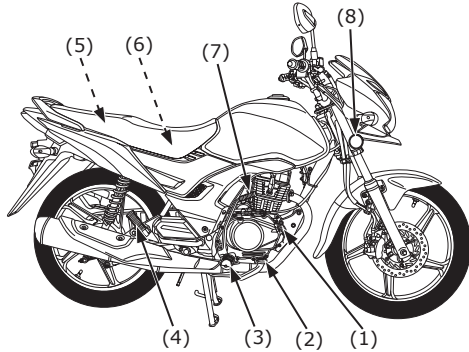

Left Side View

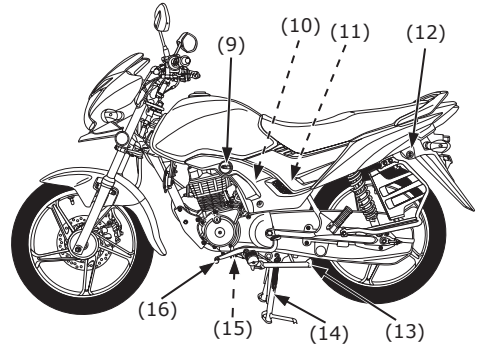

(1) Oil filler cap/Dipstick (ऑयल फिलर कैप/डिपस्टिक)	(9) Fuel valve (फ्यूल वाल्व)
(2) Rear brake pedal (रियर ब्रेक पैडल)	(10) Battery (बैटरी)
(3) Footpeg (फुटपैग)	(11) Main fuse (मैन फ्यूज)
(4) Pillion rider footpeg (पिलियन राइडर फुटपैग)	(12) Seat lock (सीट लॉक)
(5) Storage compartment (स्टोरेज कम्पार्टमेंट)	(13) Side stand (साइड स्टैंड)
(6) Air cleaner (एयर क्लीनर)	(14) Center stand (सेंटर स्टैंड)
(7) Kickstarter (किकस्टार्टर)	(15) Engine oil drain plug (इंजन ऑयल ड्रेन प्लग)
(8) Reflector (रिफ्लेक्टर)	(16) Gearshift pedal (गियर शिफ्ट पैडल)

SERIAL NUMBERS

The frame and engine serial numbers are required when registering your vehicle. They may also be required by your dealer when ordering replacement parts.

The frame number (1) is stamped on the right side of the steering head. The engine number (2) is stamped on the left side of the crankcase.

Record the numbers here for your reference.

FRAME NO. _____

ENGINE NO. _____

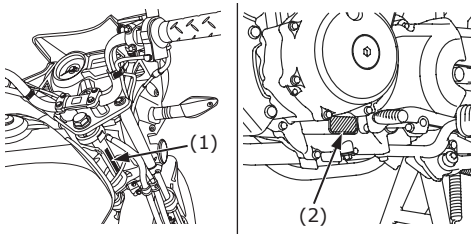

(1) Frame number (फ्रेम नम्बर)

(2) Engine number (इंजन नम्बर)

INSTRUMENT AND INDICATORS

The indicators are contained in the instrument panel. Their functions are described in the tables on the following pages.

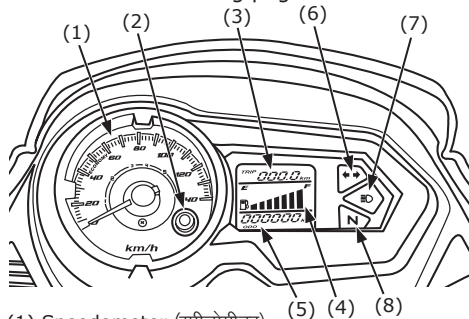

(1) Speedometer (स्पीडोमीटर)

(2) Reset button (रीसेट बटन)

(3) Tripmeter (ट्रिपमीटर)

(4) Fuel meter (फ्यूल मीटर)

(5) Odometer (ऑडोमीटर)

(6) Turn signal indicator (टर्न सिगनल इंडिकेटर)

(7) High beam indicator (हाई बीम इंडिकेटर)

(8) Neutral indicator (न्यूट्रल इंडिकेटर)

(Ref.No.) Description	Function
(1) Speedometer	Shows riding speed.
(2) Reset button	To reset tripmeter use this button.
(3) Tripmeter	Its shows distance travelled since the time it was last reset to zero.
(4) Fuel meter	Shows approximate fuel supply available (page 12).
(5) Odometer	Shows accumulated mileage.
(6) Turn signal indicator (green)	Flashes when any of the turn signal operates.
(7) High beam indicator (blue)	Indicate when the headlight is glowing on high beam.
(8) Neutral indicator (green)	Indicate when the transmission is in neutral.

Tripmeter

To reset the tripmeter proceed as follows:
Press the reset button to select Tripmeter.

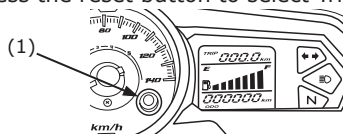

(1) Reset button (रीसेट बटन)

To reset the tripmeter, press and hold the reset button for more than 3 seconds when the display is in the "Trip".

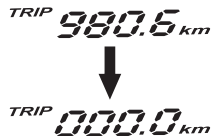

Fuel Meter

When the fuel meter display flashing and enters in the last band (2), fuel will be low. and you should refill the tank as soon as possible. The amount of fuel left in the tank with the vehicle set upright when fuel meter display flashing in last band is approximately:

1.9 L (0.50 US gal, 0.42 Imp gal)

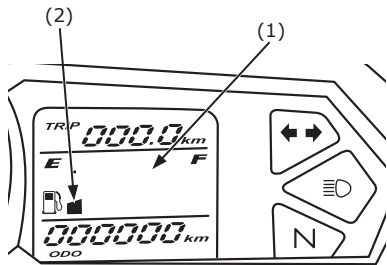

(1) Fuel meter (फ्यूल मीटर)

(2) Last band (आखरी बैंड)

MAJOR COMPONENTS

(Information you need to operate this vehicle)

SUSPENSION

The shock absorber (1) has 5 adjustment positions for different load or riding conditions.

Use a pin spanner (2) to adjust the rear shock absorber. Turning the spring preload adjuster (3) counterclockwise makes the shock absorber firm, and turning clockwise makes it soft.

Always adjust the shock absorber position in sequence (1-2-3-4-5 or 5-4-3-2-1).

Attempting to adjust directly from 5 to 1 may damage the shock absorber.

Position 5 increases spring preload for a stiffer rear suspension, and can be used when the motorcycle is heavily loaded.

NOTICE

For rear shock absorber adjustment visit to your nearest Honda dealer.

Standard position: 2

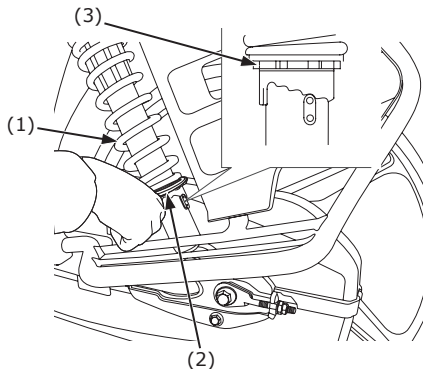

- (1) Shock absorber (शॉक एबजाबर्बर)
- (2) Pin spanner (पिन स्पैनर)
- (3) Spring preload adjuster (स्प्रिंग प्रीलोड एडजस्टर)

BRAKES

Front Brake (Disc & CBS)

This vehicle has a front hydraulic and rear mechanical drum brake.

As the brake pads wear, brake fluid level drops.

There are no adjustments to perform, but fluid level and pad wear must be inspected periodically. The system must be inspected frequently to ensure there are no fluid leaks. If the control lever free travel becomes excessive and the brake pads are not worn beyond the recommended limit (page 62), there is probably air in the brake system and it must be bled. See your Honda dealer for this service.

Front Brake Fluid Level:

With the vehicle in an upright position, check the fluid level. It should be above the lower level mark (1). If the level is at or below the lower level mark (1), check the brake pads for wear (page 62).

Worn pads should be replaced. If the pads are not worn, have your brake system inspected for leaks.

The recommended brake fluid is Honda DOT 3 or 4 brake fluid from a sealed container, or an equivalent.

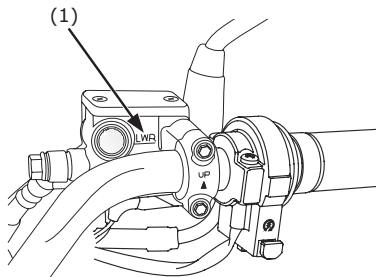

(1) Lower level mark (निचला स्तर चिन्ह)

Other Checks:

Make sure there are no fluid leaks. Check for deterioration or cracks in the hoses and fittings.

Front Brake (Drum type)

Brakes are items of personal safety and should always be maintained in proper adjustment.

The distance the front brake lever or rear brake pedal moves before the brake starts to engage is called freeplay.

Measured at the tip of the front brake lever (1), freeplay should be maintained at:

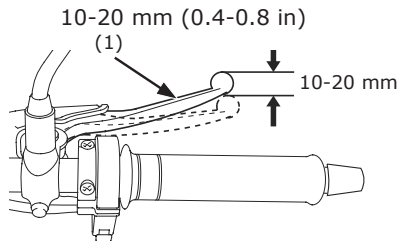

(1) Front brake lever (फ्रंट ब्रेक लीवर)

Adjustment:

1. Front brake adjustment should be made using the front brake adjusting nut (2) at the front wheel.

2. Adjust the brake lever free play with the front brake-adjusting nut. Turning the nut clockwise will decrease freeplay and turning the nut counterclockwise will increase freeplay.

Make sure the cut-out on the adjusting nut is seated on the brake arm pin (3) after making final freeplay adjustment.

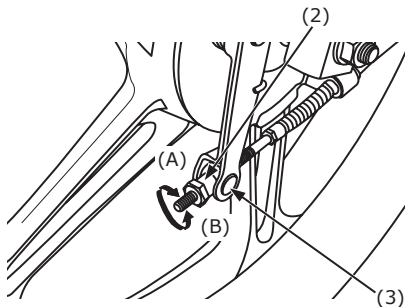

- (2) Front brake adjusting nut (फ्रंट ब्रेक एडजस्टिंग नट)
(3) Brake arm pin (ब्रेक आर्म पिन)
(A) Decrease free play (फ्री प्ले घटाएँ)
(B) Increase free play (फ्री प्ले बढ़ाएँ)

Apply the brake several times and check for free wheel rotation after the brake lever is released.

If proper adjustment cannot be obtained by this method, see your Honda dealer.

Other Checks:

Check the brake cable for kinks or signs of wear that could cause sticking or failure.

Lubricate the brake cable with a commercially available cable lubricant to prevent premature wear and corrosion

Make sure the brake arm, spring and fasteners are in good condition.

REAR BRAKE

Adjustment:

1. Place the vehicle on its center stand.
2. Measure the distance the rear brake pedal (1) moves before the brake starts to take hold.

Free play should be:

20 -30 mm (0.8 -1.2 in)

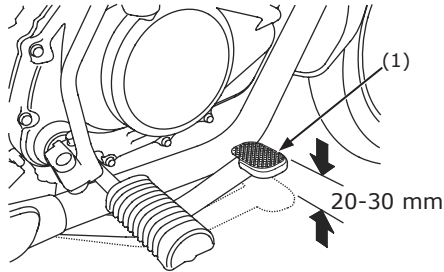

(1) Rear brake pedal (रियर ब्रेक पैडल)

3. If adjustment is necessary, turn the rear brake adjusting nut (2).

Make sure the cut-out on the adjusting nut is seated on the brake arm pin (3) after making final free play adjustment.

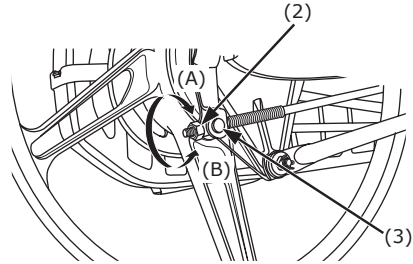

(2) Rear brake adjusting nut (रियर ब्रेक एडजस्टिंग नट)

(3) Brake arm pin (ब्रेक आर्म पिन)

(A) Decrease free play (फ्री प्ले घटाएँ)

(B) Increase free play (फ्री प्ले बढ़ाएँ)

4. Apply the brake several times and check for free wheel rotation after the brake pedal is released.

If proper adjustment cannot be obtained by this method, see your Honda dealer.

After adjustment, push the brake arm to confirm that there is a gap between the rear brake adjusting nut and the brake arm pin.

After adjustment, confirm the free play of the brake pedal.

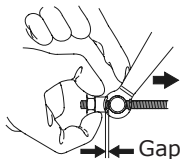

Cut out correctly seated



Cut out not seated



Other Checks:

Make sure the brake arm, spring and fasteners are in good condition.

Rear Brake Fluid Level: (for CBS)

With the vehicle in a side right position, check the fluid level. It should be above the LOWER level mark (1). If the level is at or below the LOWER level mark, check the brake pads for wear (page 62).

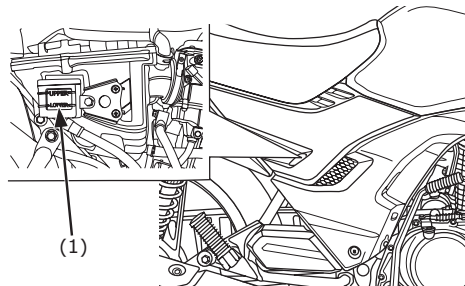

(1) LOWER level mark (निचला स्तर चिन्ह)

Worn pads should be replaced. If the pads are not worn, have your brake system inspected for leaks.

The recommended brake fluid is Honda DOT 3 or 4 brake fluid from a sealed container, or an equivalent.

Other Checks:

Make sure there are no fluid leaks. Check for deterioration or cracks in the hoses and fittings.

CLUTCH

Clutch adjustment may be required if the vehicle stalls when shifting into gear or tends to creep; or if the clutch slips, causing acceleration to lag behind engine speed. Normal clutch lever free play is:

10 -20 mm (0.4 -0.8 in)

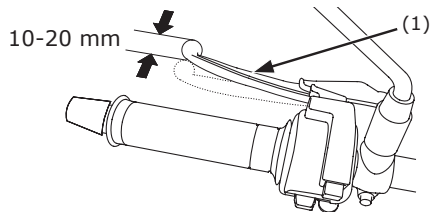

(1) Clutch lever (क्लच लीवर)

1. Loosen the lock nut (2) at the lower end of the cable. Turn the adjusting nut (3) to obtain the specified free play. Tighten the lock nut and check the adjustment.
2. Start the engine, pull in the clutch lever and shift into gear. Make sure the engine does not stall and the vehicle does not creep. Gradually release the clutch lever and open the throttle. The vehicle should begin to move smoothly and accelerate gradually.

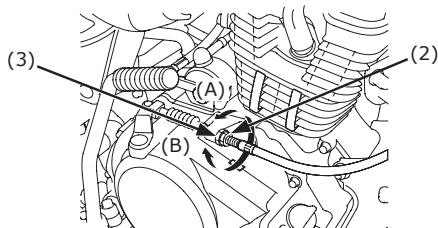

(2) Lock nut (लॉक नट)

(3) Adjusting nut (एडजस्टिंग नट)

(A) Increase free play (फ्री प्ले बढ़ाएँ)

(B) Decrease free play (फ्री प्ले घटाएँ)

If proper adjustment cannot be obtained or the clutch does not work correctly, see your Honda dealer.

Other Checks:

Check the clutch cable for kinks or signs of wear that could cause sticking or failure. Lubricate the clutch cable with a commercially available cable lubricant to prevent premature wear and corrosion.

FUEL

Fuel Valve

The three way fuel valve (1) is on the left side below the fuel tank.

ON

With the fuel valve in the ON position, fuel will flow from the main fuel supply to the carburetor.

OFF

With the fuel valve in the OFF position, fuel cannot flow from the tank to the carburetor. Turn the valve to OFF position whenever the vehicle is not in use.

RES

With the fuel valve in this RES position, fuel will flow from the reserve fuel supply to the carburetor. Use the reserve fuel only when the main supply is gone. Refill the tank as soon as possible after switching to RES.

The reserve fuel supply is:

1.9 Ltr. (0.50 US gal , 0.42 Imp gal)

Remember to check that the fuel valve is in the ON position each time you refuel. If the valve is left in the RES position, you may run out of fuel with no reserve.

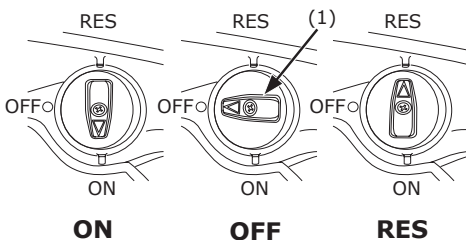

(1) Fuel valve (फ्यूल वाल्व)

Fuel Tank

The fuel tank capacity including the reserve supply is:

10.5 Ltr. (2.77 US gal , 2.31 Imp gal)

To open the fuel fill cap (1), insert the ignition key (2) and turn it clockwise. The fuel fill cap will pop up and can be lifted off. Do not overfill the tank. There should be no fuel in the filler neck (3).

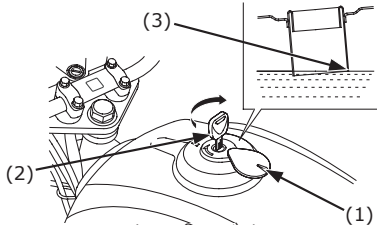

(1) Fuel fill cap (फ्यूल फिल कैप)

(2) Ignition key (इग्निशन की)

(3) Filler neck (फिलर नैक)

After refueling, to close the fuel fill cap, align the latch in the cap with the slot in the filler neck. Push the fuel fill cap into the

filler neck until it snaps closed and locks. Remove the key.

! WARNING

Petrol is highly flammable and explosive. You can be burned or seriously injured when handling fuel.

- Stop the engine and keep heat, sparks, and flame away.
- Refuel only outdoors.
- Wipe up spills immediately.

Use unleaded petrol with a research octane number of 88 or higher.

The use of leaded petrol will cause premature damage to the catalytic converter.

NOTICE

If "spark knock" or "pinking" occurs at a steady engine speed under normal load, change brands of petrol. If spark knock or pinking persists, consult your Honda dealer. Failure to do so is considered misuse, and damage caused by misuse is not covered by Honda's Limited Warranty.

EVAPORATIVE EMISSION CONTROL SYSTEM

This vehicle is equipped with evaporative emission (EVAP) canister, which is designed to keep gasoline from evaporating into the atmosphere. Rather than venting a gas tank to the atmosphere.

If the problem occurs, contact your Honda dealer.

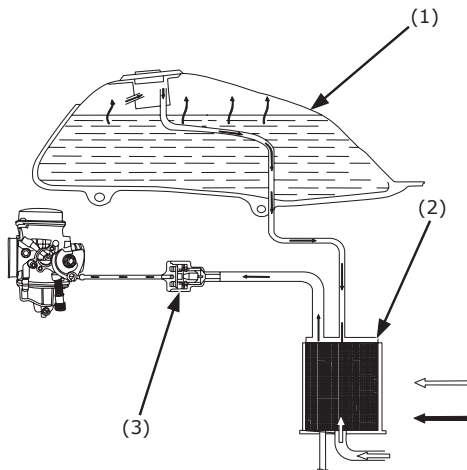

- (1) Fuel tank (फ्यूल टैंक)
- (2) Canister (कैनिस्टर)
- (3) One way valve (वन वे वॉल्व)

Petrol Containing Alcohol

If you decide to use a petrol containing alcohol (gasohol), be sure it's octane rating is at least as high as that recommended by Honda.

- When certain types of petrol containing alcohol are used, problems such as hard starting, poor performance, etc. may occur.
- If you notice any undesirable operating symptoms while using a petrol that contains alcohol, or one that you think contains alcohol, try another station or switch to another brand of petrol.
- When a problem resulting from the use of petrol containing alcohol occurs, contact your Honda dealer.

WARNING

Adulterated fuel not to be used. It causes damage to the engine parts and considered as misuse, damage caused by misuse is not covered under Honda warranty.

ENGINE OIL

Engine Oil Level Check

Check the engine oil level each day before riding the vehicle.

The level must be maintained between the upper (1) and lower (2) level marks on the oil filler cap/dipstick (3).

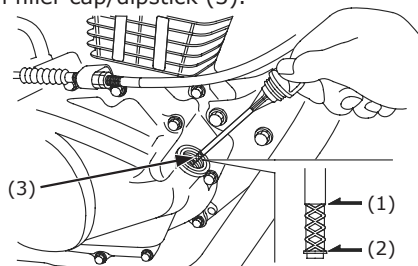

- (1) Upper level mark (ऊपरी स्तर चिन्ह)
- (2) Lower level mark (निचला स्तर चिन्ह)
- (3) Oil filler cap/dipstick (ऑयल फिलर कैप / डिपस्टिक)

1. Start the engine and let it idle for 3-5 minutes.
2. Stop the engine and put the vehicle on its center stand on level ground.

3. After 2-3 minutes, remove the oil filler cap/dipstick, wipe it clean, and reinsert the oil filler cap/dipstick without screwing it in. Remove the oil filler cap/ dipstick. The oil level should be between the upper and lower marks on the oil filler cap/dipstick.
4. If required, add the specified oil (see page 44) up to the upper level mark. Do not overfill.
5. Reinstall the oil filler cap/dipstick. Check for oil leaks.

NOTICE

Running the engine with insufficient oil pressure may cause serious engine damage.

TYRES

To safely operate your vehicle, your tyres must be the proper type and size, in good condition with adequate tread, and correctly inflated for the load you are carrying. The following pages give more detailed information on how and when to check your air pressure, how to inspect your tyres for damage, and what to do when your tyres need to be repaired or replaced.

WARNING

Using tyres that are excessively worn or improperly inflated can cause an accident in which you can be seriously hurt or killed.

Follow all instructions in this owner's manual regarding tyre inflation and maintenance.

Air Pressure

Keeping your tyres properly inflated provides the best combination of handling, tread life and riding comfort. Generally, under inflated tyres wear unevenly, adversely affect handling, and are more likely to fail from being overheated.

Over inflated tyres make your vehicle ride more harsh, are more prone to damage from road hazards, and wear unevenly.

We recommend that you visually check your tyres before every ride and use a gauge to measure air pressure at least once a month or any time you think the tyres might be low.

Always check air pressure when your tyres are “cold” when the vehicle has been parked for at least three hours. If you check air pressure when your tyres are “warm” when the vehicle has been ridden for even a few miles the readings will be higher than if the tyres were “cold”. This is normal, so do not let air out of the tyres to match the recommended cold air pressures given below. If you do, the tyres will be under inflated.

The recommended “cold” tyre pressures are:

kPa (kgf/cm ² , psi)		
Rider Only	Front	175 (1.75 , 25)
	Rear	225 (2.25 , 33)
Rider and one pillion rider	Front	175 (1.75 , 25)
	Rear	280 (2.80 , 41)

This vehicle is fitted with tubeless tyre in both wheels. Compared with ordinary tube tyre, the tubeless tyre releases slow air leak when punctured by a nail or other

similar object. For this reason, even though they remain fully inflated, it is important to regularly check the tyre for embedded objects.

Inspection

Whenever you check the tyre pressures, you should also examine the tyre treads and side walls for wear, damage, and foreign objects:

Look for:

- Bumps or bulges on the side of the tyre tread. Replace the tyre if you find any bumps or bulges.
- Cuts, splits or cracks in the tyre. Replace the tyre if you can see fabric or cord.
- Excessive tread wear.

Also, if you hit a pothole or hard object, pull to the side of the road as soon as you safely can and carefully inspect the tyres for damage.

Tread Wear

Replace tyres before tread depth at the center of the tyre reaches the following limit:

Minimum tread depth	
Front:	1.5 mm (0.06 in)
Rear	2.0 mm (0.08 in)

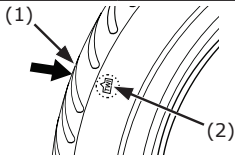

- (1) Wear indicator (वियर इंडिकेटर)
(2) Wear indicator location mark
(वियर इंडिकेटर लोकेशन चिन्ह)

Tyre Repair

If a tubeless tyre is punctured or damaged, Please visit nearest tyre manufacture dealer and follow his recommendation for repair or replacement.

⚠ CAUTION

Repair/Replacement of tubeless tyre by unauthorized person may render the tyre useless or tyre can fail while driving.

Tyre Replacement

The tyres that came on your vehicle were designed to match the performance capabilities of your vehicle and provide the best combination of handling, braking, durability and comfort.

⚠ WARNING

Using tyres that are excessively worn or improperly inflated can cause a crash in which you can be seriously hurt or killed. Follow all instructions in this owner's manual regarding tyre inflation and maintenance.

The recommended tyres for your vehicle are:

Front: 80/100-18M/C 47P

Rear: 80/100-18M/C 54P

Whenever you replace a tyre, use one that is equivalent to the original and be sure the wheel is balanced after the new tyre is installed.

ESSENTIAL INDIVIDUAL COMPONENTS

IGNITION SWITCH

The ignition switch (1) is below the speedometer.

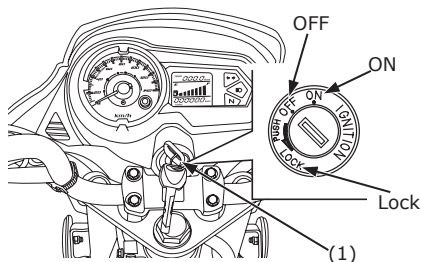

(1) Ignition switch (इग्नीशन स्विच)

Key Position	Function	Key Removal
LOCK (steering lock)	Steering is Locked. Engine and lights cannot be operated.	Key can be removed
OFF	Engine and lights cannot be operated.	Key can be removed
ON	Engine and lights can be operated Turn signal, passing light control switch and horn can be operated.	Key cannot be removed

RIGHT HANDLEBAR CONTROLS

Starter Button (1)

The starter button (1) is next to the throttle grip.

When the starter button is pressed the starter motor cranks the engine. See page 33 for the starting procedure.

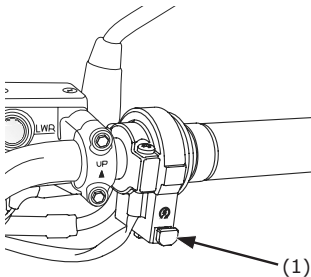

(1) Starter button (स्टार्टर बटन)

LEFT HANDLEBAR CONTROLS



NOTICE

Automatic Headlamp ON (AHO Compliance):-

This means that the Headlamp will get ON as soon as the engine is started.

There is no switch to turn OFF the Headlamp while riding. "Automatic Headlamp ON" feature of your vehicle helps other to recognize your vehicle position in foggy/dusty environment condition.

Headlight Dimmer Switch (1)

Push the dimmer switch to  (HI) to select high beam or to  (LO) to select low beam.

Passing Light Control Switch (2)

When this switch is pressed, the headlight flashes on to signal approaching cars or when passing.

Turn Signal Switch (3)

Move to ← (L) to signal a left turn, → (R) to signal a right turn. Press to turn signal off.

Horn Button (4)

Press the button to sound the horn.

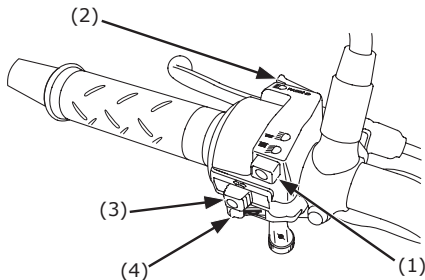

- (1) Headlight dimmer switch (हैडलाइट डिमर स्विच)
- (2) Passing light control switch (पासिंग लाइट कन्ट्रोल स्विच)
- (3) Turn signal switch (टर्न सिगनल स्विच)
- (4) Horn button (हॉर्न बटन)

FEATURES

(Not required for operation)

STEERING LOCK

To lock the steering, turn the handlebar all the way to the left or right, turn the key (1) to LOCK while pushing in. Remove the key. To unlock the steering, turn the key to OFF.

Do not turn the key to LOCK while riding the vehicle; loss of vehicle control will result.

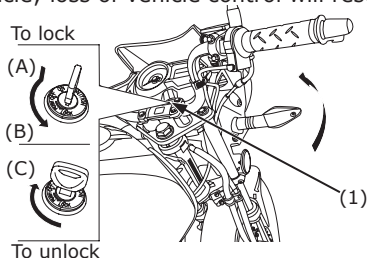

- (1) Ignition key (इग्निशन चाबी)
- (A) Push in (पुश-इन)
- (B) Turn to LOCK (लॉक की ओर घुमाएँ)
- (C) Turn to OFF (ऑफ की ओर घुमाएँ)

HEADLIGHT AIM VERTICAL ADJUSTMENT

Vertical adjustment can be made by moving the headlight assembly as necessary. To move the headlight assembly, loosen the bolt (1).

Tighten the bolt after adjustment.

Obey local laws and regulations.

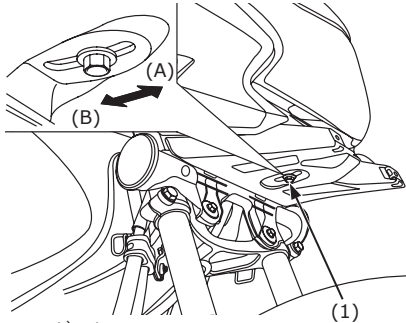

- (1) Bolt (बोल्ट)
- (A) Up (ऊपर)
- (B) Down (नीचे)

LEFT SIDE COVER

The left side cover must be removed for battery & fuse maintenance.

Removal:

1. Remove the seat (page 30).
2. Remove the screw (1).
3. Carefully pull the side cover (2) out from the grommets (3).

Installation:

- Installation can be done in the reverse order of removal.

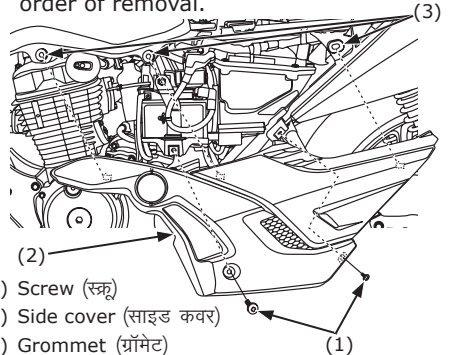

- (1) Screw (स्कू)
- (2) Side cover (साइड कवर)
- (3) Grommet (ग्रॉमेट)

SEAT

The seat (1) must be removed for air cleaner inspection, to remove the right & left side cover or to access the tool kit, first aid kit and owner's manual.

Removal:

1. Insert the ignition key (2) into the seat lock (3) and turn it clockwise.

Installation:

1. Align the front prongs (4) under the front of the seat with the recess (5) under the frame cross member, and locating the rear prongs (6) on the bottom of the seat with the hooks (7) on the frame.
2. Slide the seat into position and push down on the rear of the seat.

Be sure the seat is locked securely in position after installation.

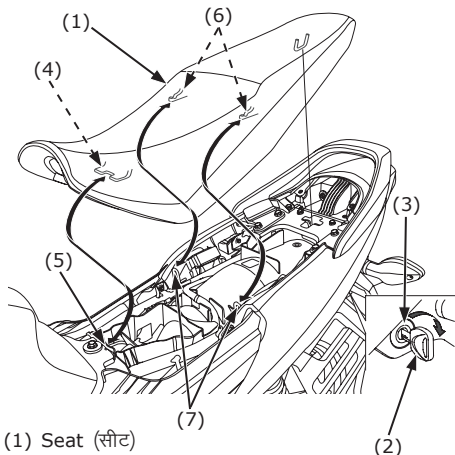

- (1) Seat (सीट)
- (2) Ignition key (इग्निशन चाबी)
- (3) Seat lock (सीट लॉक)
- (4) Front prong (आगे का प्रॉंग)
- (5) Recess (रेसिस)
- (6) Rear prongs (पीछे का प्रॉंग)
- (7) Hooks (हूक्स)

STORAGE COMPARTMENT

The storage compartment (1) is located under the seat (page 30) . This compartment is for light weight items.

The first aid kit and tool kit should be stored in this compartment.

When washing your vehicle, be careful not to flood this area with water.

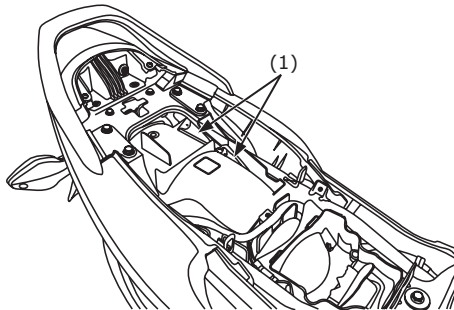

(1) Storage compartment (स्टोरेज कम्पार्टमेंट)

DOCUMENT BAG

The documents bag (1) is in the document compartment (2) on the reverse side of the seat (3).

The owner's manual and other documents should be stored in the document bag.

When washing your vehicle, be careful not to flood this area with water.

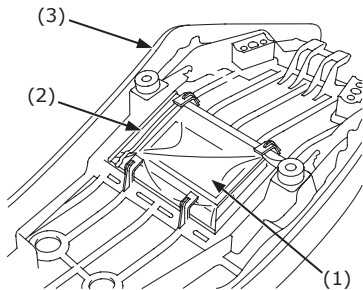

- (1) Document bag (डॉक्यूमेंट बैग)
- (2) Document compartment (डॉक्यूमेंट कम्पार्टमेंट)
- (3) Seat (सीट)

OPERATION

PRE-RIDE INSPECTION

For your safety, it is very important to take a few moments before each ride to walk around your vehicle and check its condition. If you detect any problem, be sure you take care of it, or have it corrected by your Honda dealer.

WARNING

Improperly maintaining this motorcycle or failing to correct a problem before riding can cause a crash in which you can be seriously hurt or killed.

Always perform a pre-ride inspection before every ride and correct any problems.

1. Engine oil level - add engine oil if required (page 22). Check for leaks.
2. Fuel level - fill fuel tank when necessary (page 20). Check for leaks.

3. Front and Rear brakes - check operation;
Front: make sure there is no brake fluid leakage (pages 13-15).
Rear: adjust free play if necessary (pages 16-17).
Rear: make sure there is no brake fluid leakage (pages 17). (in case of CBS)
4. Tyres - check condition and pressure (pages 23-25).
5. Drive chain - check condition and slack (page 52). Adjust and lubricate if necessary.
6. Throttle - check for smooth opening and full closing in all steering positions.
7. Clutch - check operation, and adjust if necessary (pages 18-19).
8. Lights and horn - check that turn signals, indicators and horn function properly.

STARTING THE ENGINE

Always follow the proper starting procedure described below.

This vehicle can be started with the transmission in gear by disengaging the clutch before operating the electric starter/kickstarter.

To protect the catalytic converter in your vehicle's exhaust system, avoid extending idling and the use of leaded petrol.

Your vehicle's exhaust contains poisonous carbon monoxide gas. High levels of carbon monoxide can collect rapidly in enclosed areas such as a garage. Do not run the engine with the garage door closed. Even with the door open, run the engine only long enough to move your vehicle out of the garage.

Do not operate the kickstarter pedal while the engine is running as engine damage could result. Do not apply excessive force on the kickstarter pedal.

Fold up the kickstarter pedal after the kickstarter is returned to the pedal stop.

Do not use the electric starter for more than 5 second at a time. Release the starter button for approximately 10 seconds before pressing it again.

Preparation

Before starting, insert the key, turn the ignition switch ON and confirm the following:

- The transmission is in NEUTRAL (neutral indicator light ON).
- The fuel valve is ON.

Starting Procedure

To restart a warm engine follow the procedure for High Air Temperature.

Normal Air Temperature (10°C to 35°C):

1. Move the choke lever (1) left all the way to Fully ON (A), if the engine is cold.

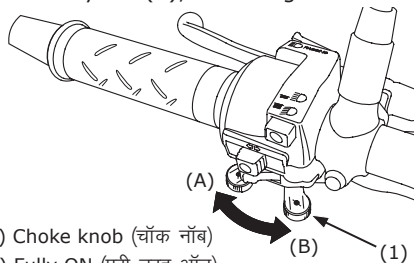

- (1) Choke knob (चॉक नॉब)
(A) Fully ON (पूरी तरह ऑन)
(B) Fully OFF (पूरी तरह ऑफ)

2. **a <Using the electric starter>**

With the throttle closed, press the starter button.

b <Using the kickstarter pedal>

Lightly depress the kickstarter until resistance is felt.

Then let the kickstarter return to the top of its stroke.

With the throttle closed, operate the kickstarter.

Kick from the top of the stroke through to the bottom with a rapid, continuous motion.

3. Immediately after the engine start, operate the choke lever to keep fast idle.
4. About 15 seconds after the engine start, move the choke lever right all the way to fully OFF (B).
5. If idling is unstable, open the throttle slightly.

High Air Temperature (35°C or Above):

1. Do not use the choke.

2. **a <Using the electric starter>**

With the throttle slightly open, press the starter button.

b <Using the kickstarter pedal>

Lightly depress the kickstarter until resistance is felt.

Then let the kickstarter return to the top of its stroke.

With the throttle closed, operate the kickstarter.

Kick from the top of the stroke through to the bottom with a rapid, continuous motion.

Low Air Temperature (10°C or below):

1. Follow **Step 1 & 2** from "Normal Air Temperature" starting procedure.
2. When engine speed begins to pick up, operate the choke lever to keep fast idle.
3. Continue warming up the engine until it runs smoothly and responds to the throttle when the choke lever is at fully OFF (B).

Flooded Engine

If the engine fails to start after repeated attempts, it may be flooded with excess fuel.

(Use the start button)

To clear a flooded engine, turn the ignition switch to ON, and move the choke knob to fully OFF (B). Open the throttle fully and crank the engine for 5 seconds. If the engine starts, quickly close the throttle, then open it slightly if idling is unstable. If the engine does not start, Wait for 10 seconds, then follow the starting procedure.

(Use the kickstarter)

To clear a flooded engine, turn OFF the ignition switch and move the choke knob to fully OFF (B). Open the throttle fully and crank the engine several times with the kickstarter. Turn the ignition switch to ON and open the throttle slightly; start the engine using the kickstarter.

RUNNING-IN

Help assure your vehicle's future reliability and performance by paying extra attention to how you ride during the first 500 km (300 miles).

During this period, avoid full-throttle starts and rapid acceleration.

RIDING

Review Vehicle Safety (page 3-7) before you ride.

Make sure the side stand is fully retracted before riding the vehicle. If the stand is extended, it may interfere with control during a left turn.

1. After the engine has been warmed up, the vehicle is ready for riding.
2. While the engine is idling, pull in the clutch lever and depress the gearshift pedal to shift into 1st (low) gear.
3. Slowly release the clutch lever and at the same time gradually increase engine speed by opening the throttle.

Coordination of the throttle and clutch lever will assure a smooth positive start.

4. When the vehicle attains a moderate speed, close the throttle, pull in the clutch lever and shift to 2nd gear by raising the gearshift pedal.
5. Coordinate the throttle and brakes for smooth deceleration.
6. Both front and rear brakes should be used at the same time and should not be applied strongly enough to lock the wheel, or braking effectiveness will be reduced and control of the vehicle be difficult.

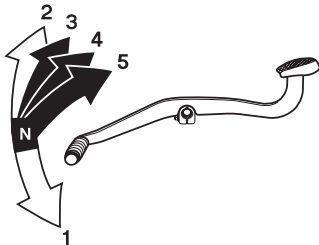

BRAKING

Your vehicle is equipped with a hydraulically activated disc brake in front and mechanically operated rear brakes. Operating the brake lever applies the front disc brake. Depressing the brake pedal applies the rear brake.

(For Drum & Disc)

For normal braking, apply both the brake pedal and lever while down-shifting to match your road speed. For maximum braking, close the throttle and firmly apply the pedal and lever; pull in the clutch lever before coming to a complete stop to prevent stalling the engine.

(For CBS)

Both brakes can be applied with the help of rear brake pedal only. However, for more effective braking, it is advised to apply both front and rear brake simultaneously

Important Safety Reminders:

- Independent operation of only the brake lever or brake pedal reduces stopping performance in case of disc and drum brake variant.

- Extreme application of the brake controls may cause wheel lock, reducing control of the vehicle.
- When possible, reduce speed or brake before entering a turn; closing the throttle or braking in mid-turn may cause wheel slip. Wheel slip will reduce control of the vehicle.
- When riding in wet or rainy conditions, or on loose surfaces, the ability to manoeuvre and stop will be reduced. All of your actions should be smooth under these conditions. Rapid acceleration, braking or turning may cause loss of control. For your safety, exercise extreme caution when braking, accelerating or turning.
- When descending a long, steep grade, use engine compression braking by downshifting, with intermittent use of both brakes.
- Continuous brake application can overheat the brakes and reduce their effectiveness.
- Riding with your foot resting on the brake pedal or your hand on the brake

lever may actuate the brakelight, giving a false indication to other drivers. It may also overheat the brakes, reducing effectiveness.

PARKING

1. After stopping the vehicle, shift the gear into neutral, turn the fuel valve OFF, turn the handlebar fully to the left/right, turn the ignition switch OFF, LOCK the handlebar and remove the key.
2. Use the center stand to support the vehicle while parked..
Park the vehicle on firm, level ground to prevent it from falling over. If you must park on a slight incline, aim the front of the vehicle uphill to reduce the possibility of rolling off the center stand or overturning.
3. Lock the steering (page 28) to help prevent theft.

Make sure flammable materials such as dry grass or leaves do not come in contact with the exhaust system when parking your vehicle.

MAINTENANCE

THE IMPORTANCE OF MAINTENANCE

A well-maintained vehicle is essential for safe, economical and trouble-free riding. It will also help reduce air pollution.

To help you properly care for your vehicle, the following pages include a Maintenance Schedule and a maintenance Record for regularly scheduled maintenance.

These instructions are based on the assumption that the vehicle will be used exclusively for its designed purpose. Sustained high speed operation or operation in unusually wet or dusty conditions will require more frequent service than specified in the Maintenance Schedule. Consult your Honda dealer for recommendations applicable to your individual needs and use.

If your vehicle overturns or becomes involved in a crash, be sure your Honda dealer inspects all major parts, even if you are able to make some repairs.

⚠ WARNING

Improperly maintaining this motorcycle or failing to correct a problem before you ride can cause a crash in which you can be seriously hurt or killed.

Always follow the inspection and maintenance recommendations and schedules in this owner's manual.

MAINTENANCE SAFETY

This section includes instructions on some important maintenance tasks. You can perform some of these tasks with the tools provided- if you have basic mechanical skills.

Other tasks that are more difficult and require special tools are best performed by professionals. Wheel removal should normally be handled only by a Honda technician or other qualified mechanic; instructions are included in this manual only to assist in emergency service.

Some of the most important safety precautions follow. However, we cannot

warn you of every conceivable hazard that can arise in performing maintenance. Only you can decide whether or not you should perform a given task.

WARNING

Failure to properly follow maintenance instructions and precautions can cause you to be seriously hurt or killed.

Always follow the procedures and precautions in this owner's manual.

SAFETY PRECAUTIONS

Make sure the engine is off before you begin any maintenance or repairs. This will help eliminate several potential hazards:

- * **Carbon monoxide poisoning from engine exhaust.**

Be sure there is adequate ventilation whenever you operate the engine.

- * **Burns from hot parts.**

Let the engine and exhaust system cool before touching.

- * **Injury from moving parts.**

Do not run the engine unless instructed to do so.

- Read the instructions before you begin, and make sure you have the tools and skills required.
- To help prevent the vehicle from falling over, park it on a firm, level surface, using the center stand or a maintenance stand to provide support.
- To reduce the possibility of a fire or explosion, be careful when working around petrol or batteries. Use only nonflammable solvent, not petrol, to clean parts. Keep cigarettes, sparks and flames away from the battery and all fuel-related parts.

Remember that your Honda dealer knows your vehicle best and is fully equipped to maintain and repair it.

To ensure the best quality and reliability, use only new genuine Honda parts or their equivalents for repair and replacement.

MAINTENANCE SCHEDULE

Perform the pre-ride Inspection (Ref. page 32) at each scheduled maintenance period.

I: INSPECT, CLEAN, ADJUST, LUBRICATE OR REPLACE IF NECESSARY

C: CLEAN R: REPLACE A: ADJUST L: LUBRICATE.

The following Maintenance Schedule specifies all maintenance required to keep your vehicle in peak operating condition. Maintenance work should be performed in accordance with standards and specifications of Honda by properly trained and equipped technicians. Your Honda dealer meets all of these requirements.

- * Should be serviced by your Honda dealer, unless the owner has the proper tools and service data and is mechanically qualified. Refer to the Official Honda Shop Manual.
- ** In the interest of safety, we recommend these items be serviced only by your Honda dealer.

Honda recommends that your Honda dealer should road test your vehicle after each periodic maintenance is carried out.

- NOTES: (1) At higher odometer reading, repeat at the frequency interval established here.
- (2) Service more frequently when riding in unusually wet or dusty areas.
 - (3) Service more frequently when riding in rain or at full throttle.
 - (4) Replacement requires mechanical skill.

ITEM	FREQUENCY	NOTE	PRE-RIDE CHECK	ODOMETER READING (NOTE 1)										ANNUAL CHECK	REGULAR REPLACE	REFER TO PAGE
				X1000KM	1	4	8	12	16	20	24					
				X1000MI	0.6	2.5	5	7.5	10	12.5	15					
MONTHS	1	4	8	12	16	20	24									
* FUEL LINE						I	I	I	I	I	I	I			-	
FUEL LEVEL		I													-	
* FUEL STRAINER SCREEN						C	C	C	C	C	C				-	
* THROTTLE OPERATION		I				I	I	I	I	I	I	I			50	
* CHOKE OPERATION						I	I	I	I	I	I	I			33	
* AIR CLEANER	NOTE (2)								R						51	
CRANKCASE BREATHER	NOTE (3)					C	C	C	C	C	C	C			46	
SPARK PLUG						I	R	I	R	I	R				46	
* VALVE CLEARANCE						I	I	I	I	I	I	I			48	
ENGINE OIL		I				R	R	R	R	R	R	R	R		44	
** ENGINE OIL STRAINER SCREEN						C			C			C			-	
** ENGINE OIL CENTRIFUGAL FILTER									C			C			-	
* ENGINE IDLE SPEED						I	I	I	I	I	I	I	I		50	
* SECONDARY AIR SUPPLY SYSTEM										I			I		-	
* EVAPORATIVE EMISSION CONTROL SYSTEM									I			I			-	

The vehicle must be serviced at every 4000 kms or within 4 months whichever is earlier from the date of previous service. For NOTES refer page 40.

ITEM	FREQUENCY	NOTE	PRE-RIDE CHECK	ODOMETER READING (NOTE 1)										ANNUAL CHECK	REGULAR REPLACE	REFER TO PAGE
				X1000KM	1	4	8	12	16	20	24					
				X1000MI	0.6	2.5	5	7.5	10	12.5	15					
				MONTHS	1	4	8	12	16	20	24					
DRIVE CHAIN	NOTE (4)	I	EVERY 1000 km (600 mil) I, L												52	
* BATTERY VOLTAGE		I	I	I	I	I	I	I	I	I	I			-		
BRAKE FLUID (for Disc & CBS)	NOTE (4)	I		I	I	I	I	I	I	I	I	2 YEARS	13,17			
BRAKE SHOES WEAR (for Drum)		I		I	I	I	I	I	I	I	I		63			
BRAKE SHOES/PADS WEAR (for Disc & CBS)		I		I	I	I	I	I	I	I	I		62-63			
BRAKE SYSTEM		I	I	I	I	I	I	I	I	I	I		13-18			
BRAKE LIGHT SWITCH				I	I	I	I	I	I	I	I		-			
HEAD LIGHT AIM				I	I	I	I	I	I	I	I		29			
LIGHTS/HORN		I		I	I	I	I	I	I	I	I		-			
CLUTCH SYSTEM		I	I	I	I	I	I	I	I	I	I		18			
SIDE STAND				I	I	I	I	I	I	I	I		58			
* SUSPENSION				I	I	I	I	I	I	I	I		57			
* NUTS, BOLTS, FASTENERS			I		I		I		I	I			-			
** WHEELS/TYRES		I		I	I	I	I	I	I	I	I		-			
** STEERING HEAD BEARINGS			I			I			I	I			-			

The vehicle must be serviced at every 4000 kms or within 4 months whichever is earlier from the date of previous service. For NOTES refer page 40.

TOOL KIT AND FIRST AID KIT

The tool kit (1) and first aid kit (2) is in the storage compartment under the seat.

Some roadside repairs, minor adjustments and parts replacement can be performed with the tools contained in the kit.

- Tool Bag
- Spanner 14x17
- Wrench spark plug
- Driver screw (No. 2 +/-)

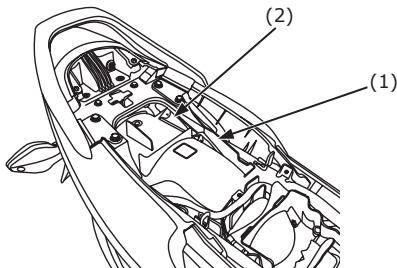

(1) Tool kit (टूल किट)

(2) First aid kit (प्राथमिक चिकित्सा किट)

COLOR CODE

The color table is attached below.

It is useful during ordering the replacement parts.

S.No.	Color	Color code
1.	Pearl Siren Blue-A	PB123
2.	Athletic Blue Metallic	PB396
3.	Geny Gray Metallic	NHA04
4.	Imperial Red Metallic	R355
5.	Black	NH1
6.	Pearl Amazing White	NHB63

The above color code table helps in providing the correct color part as per your vehicle color.

ENGINE OIL

Refer to the Safety Precautions on page 39.

ENGINE OIL

Good engine oil has many desirable qualities. Use only high detergent, quality motor oil certified on the container to meet or exceed requirements for API Service Classification MA

Viscosity:

Viscosity grade of engine oil should be based on average atmospheric temperature in your riding area. The following provides a guide to the selection of the proper grade or viscosity of oil to be used at various atmospheric temperatures.

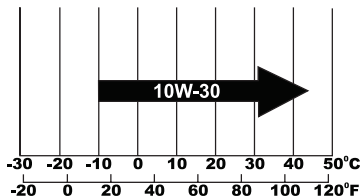

Engine Oil

Engine oil quality is the chief factor affecting engine service life. Change the engine oil as specified in the maintenance schedule (page 41).

When running in very dusty conditions, oil changes should be performed more frequently than specified in the maintenance schedule.

Please dispose of used engine oil in a manner that is compatible with the environment. We suggest you take it in a sealed container to your local recycling center or service station for reclamation. Do not throw it in the trash or pour it on the ground or down a drain.

Used engine oil may cause skin cancer if repeatedly left in contact with the skin for prolonged periods. Although this is unlikely unless you handle used oil on a daily basis, it is still advisable to thoroughly wash your hands with soap and water as soon as possible after handling used oil.

If a torque wrench is not used for this installation, see your Honda dealer as soon as possible to verify proper assembly.

Change the engine oil with the engine at normal operating temperature and the vehicle on its center stand to assure complete and rapid draining.

1. To drain the oil, remove the oil filler cap/dipstick and oil drain bolt (1) and sealing washer (2).
2. Operate the kickstarter several times to aid in complete draining of the remaining oil.
3. Check that the sealing washer on the drain bolt is in good condition and install the bolt. Replace the sealing washer every other time the oil is changed, or each time if necessary.

Oil Drain Bolt Torque:

30 N·m (3.1 kgf·m , 22 lbf·ft)

4. Fill the crankcase with the recommended grade oil; approximately:
0.9 L (0.9 US qt , 0.8 Imp qt)

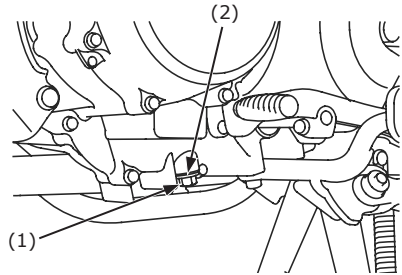

(1) Oil drain bolt (आयॅल ड्रेन बोल्ट)

(2) Sealing washer (सीलिंग वॉशर)

5. Install the oil filler cap/dipstick.
6. Start the engine and let it idle for 3-5 minutes.
7. 2-3 minutes after stopping the engine, check that the oil level is at the upper level mark on the oil filler cap/dipstick with the vehicle upright on firm, level ground. Make sure there are no oil leaks.

CRANKCASE BREATHER

Refer to the Safety Precautions on page 39.

1. Remove the left side cover (page 29).
2. Remove the crankcase breather tube plug (1) from the tube and drain deposits into a suitable container.
3. Reinstall the crankcase breather tube plug.

Service more frequently when riding in rain or at full throttle.

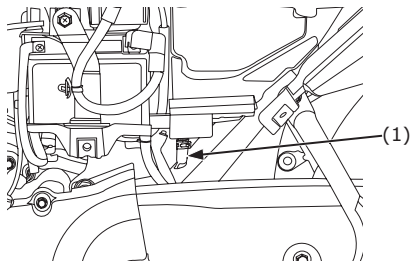

(1) Crankcase breather tube plug

(क्रैंककेस ब्रीदर ट्यूब प्लग)

SPARK PLUG

Refer to the Safety Precautions on page 39.

Recommended plug:

Standard:

CPR7EA - 9 (NGK)/ UR6DC (BOSCH)

NOTICE

Never use a spark plug with an improper heat range. Severe engine damage could result.

1. Disconnect the spark plug cap (1) from the spark plug.
2. Clean any dirt from around the spark plug base.
Remove the spark plug using the spark plug wrench (2) furnished in the tool kit.

3. Inspect the electrodes and center porcelain for deposits, erosion or carbon fouling. If the erosion or deposit is heavy, replace the plug. Clean a wetfouled plug with a plug cleaner, otherwise use a wire brush.

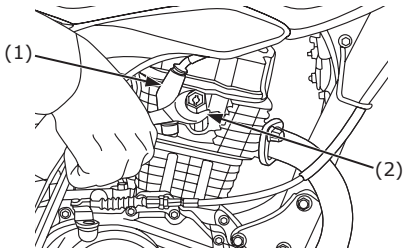

- (1) Spark plug cap (स्पार्क प्लग कैप)
 (2) Spark Plug wrench (स्पार्क प्लग रेंच)

4. Check the spark plug gap (3) using a wire-type feeler gauge. If adjustment is necessary, bend the side electrode (4) carefully.

The gap should be:

0.8 - 0.9 mm (0.03-0.04 in)

5. Make sure the plug washer is in good condition.
 6. With the plug washer attached, the spark plug in by hand to prevent cross-threading.

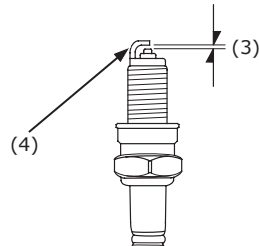

- (3) Spark plug gap (स्पार्क प्लग गैप)
 (4) Side electrode (साइड इलेक्ट्रोड)

7. Tighten the spark plug:

- If the old plug is good:
 1/8 turn after it seats.
- If installing a new plug, tighten it twice to prevent loosening:
 - a) First, tighten the plug:
 1/2 turn after it seats.
 - b) Then loosen the plug.
 - c) Next, tighten the plug again:
 1/8 turn after it seats.

NOTICE

Improperly tightened spark plug can damage the engine. If a plug is too loose, a piston may be damaged. If a plug is too tight, the threads may be damaged.

8. Reinstall the spark plug cap. Take care to avoid pinching any cables or wires.

VALVE CLEARANCE

Refer to the safety precautions on page 39. Should be serviced by your Honda dealer, unless the owner has the proper tools and service data and is mechanically qualified. Refer to the Official Honda Shop Manual.

Excessive valve clearance will cause noise and eventual engine damage. Little or no clearance will prevent the valve from closing and cause valve damage and power loss. Check the valve clearance at the specified intervals when the engine is in cold condition.

The checking or adjusting of the clearance should be performed while the engine is cold.

The clearance will change as the engine temperature rises.

1. Remove the crankshaft hole cap (1) and timing hole cap (2)
2. Remove the cylinder head cover.
3. Rotate the flywheel counterclockwise until the T Mark (3) on the flywheel lines up with the Index Mark (4) on the crankcase. In this position, the piston may either be on the compression or exhaust stroke.

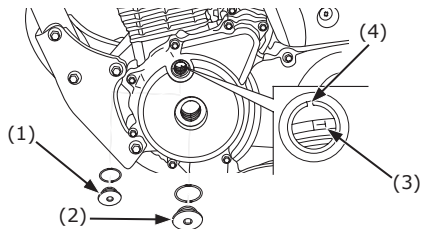

- (1) Crankshaft hole cap (क्रैंक शाफ्ट होल कैप)
- (2) Timing hole cap (टाइमिंग होल कैप)
- (3) "T" mark ('टी' मार्क)
- (4) Index mark (इंडैक्स मार्क)

The adjustment must be made when the piston is at the top of the compression stroke when both the intake and exhaust valves are closed.

This condition can be determined by moving the rocker arms. If they are free, it is an indication that the valves are closed and that the piston is on the compression stroke. If they are tight and the valves are open, rotate the flywheel 360° and realign the "T" mark to the index mark.

4. Check the clearance of both valves by inserting a feeler gauge (5) between the adjusting screw (6) and the valve stem.

Clearance should be:

Intake:0.08 mm (0.003 in)

Exhaust:0.12 mm (0.005 in)

If it is necessary to make an adjustment, loosen the adjusting screw lock nut (7) and turn the adjusting screw so there is a slight resistance when the feeler gauge is inserted.

After completing the adjustment, tighten the adjusting screw lock nut while holding the adjusting screw to prevent it from turning.

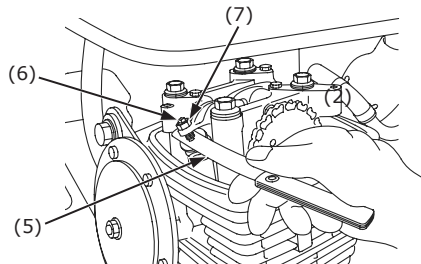

(5) Feeler gauge (फीलर गेज)

(6) Adjusting screw (एडजस्टिंग स्कू)

(7) Adjusting screw lock nut (एडजस्टिंग स्कू लॉक नट)

Finally, recheck the clearance to make sure that adjusting has not been disturbed.

IDLE SPEED

Refer to the Safety Precautions on page 39.

The engine must be at normal operating temperature for accurate idle speed adjustment. 10 minutes of stop-and-go riding is sufficient.

Do not attempt to compensate for faults in other systems by adjusting idle speed. See your Honda dealer for regularly scheduled carburetor adjustments.

1. Warm up the engine, and shift to neutral, and place the vehicle on its center stand.
2. Connect a tachometer to the engine.
3. Adjust idle speed with the throttle stop screw (1).

Idle speed (In neutral):

$1,400 \pm 100 \text{ min}^{-1} \text{ (rpm)}$

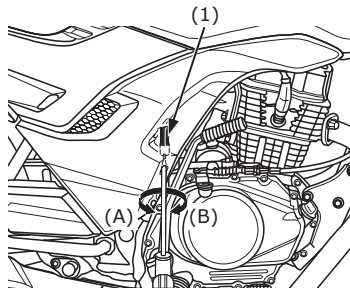

(1) Throttle stop screw (थ्रोटल स्टॉप स्कू)

(A) Increase (बढ़ाएँ)

(B) Decrease (घटाएँ)

THROTTLE OPERATION

Refer to the Safety Precautions on page 39.

1. Check for smooth rotation of the throttle grip from the fully open to the fully closed position at both full steering positions
2. Measure the throttle grip free play at the throttle grip flange.

The standard free play should be approximately:

2-6 mm (0.08-0.24 in)

To adjust the freeplay, remove the right side cover (removal procedure of right side cover is same as left side cover (page 29) removal), loosen the lock nut (1) and turn the adjuster (2).

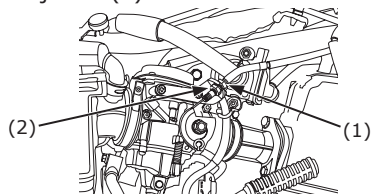

(1) Lock nut (लॉक नट)

(2) Adjuster (एडजस्टर)

AIR CLEANER

Refer to the Safety Precautions on page 39.

The air cleaner element should be replaced at regular intervals (Ref. page 41). Replace more frequently when riding in unusually wet or dusty areas.

1. Remove the seat (page 30).
2. Remove the screws (1) air cleaner rubber cover (2) and air cleaner housing cover (3).
3. Take out the air cleaner element (4) and replace.

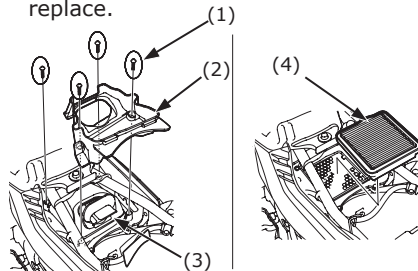

(1) Screws (स्क़ूस)

(2) Air cleaner rubber cover (एयर क्लीनर रबर कवर)

(3) Air cleaner housing cover (एयर क्लीनर हाउजिंग कवर)

(4) Air cleaner element (एयर क्लीनर ऐलीमेंट)

4. Viscous type air filters should be replaced regularly. Do not reuse it by cleaning.
5. If the filter element is cleaned using pressured air or any solvent, viscous oil

will be lost and as the base element is coarse paper, dust may enter along with air which will damage the engine.

6. Replace the air cleaner element if it is excessively dirty, torn or damaged. Use Honda genuine air cleaner element specified for your model. Using the wrong Honda air cleaner element or a non-Honda air cleaner element which is not of equivalent quality may cause premature engine wear or performance problem.
7. Install the removed parts in the reverse order of removal.

CAUTION

Do not use air, oil, water for cleaning of air cleaner element. Replacement should be done at regular intervals.

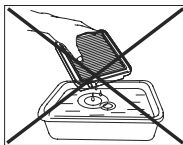
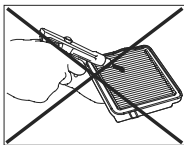

DRIVE CHAIN

Refer to the Safety Precautions on page 39.

The service life of the drive chain is dependent upon proper lubrication and adjustment. Poor maintenance can cause premature wear or damage to the drive chain and sprockets.

The drive chain should be checked and lubricated as part of the Pre-ride Inspection (page 32). Under severe usage, or when the vehicle is ridden in unusually dusty or muddy areas, more frequent maintenance will be necessary.

Inspection:

1. Turn the engine off, place the vehicle on its center stand, and shift the transmission into neutral.
2. Remove the inspection cap (1). Move the drive chain (2) up and down with your finger. Drive chain slack should be adjusted approximately to allow the following vertical movement by hand:
15 - 25 mm (0.59 - 0.98 in)

3. Rotate the rear wheel slightly and then stop to check the drive chain slackness again. Repeat this procedure several times. Drive chain slack should remain constant. If the chain is slack only in certain sections, some links are kinked and binding, kinking can be eliminated by lubrication.

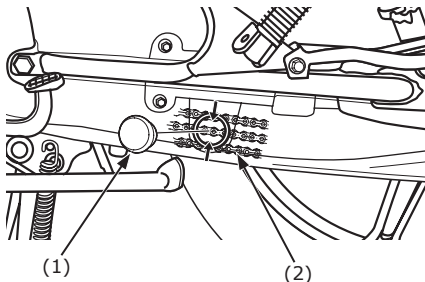

- (1) Inspection cap (निरिक्षण कैप)
- (2) Drive chain (ड्राइव चैन)

Chain Case Removal

1. Remove the bolts (1).
2. Slide the upper chain case (2) backwards away from the engine and lower chain case (3) from the swingarm carefully.

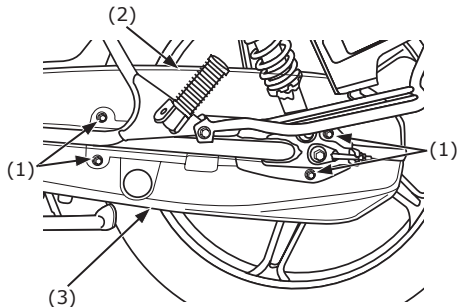

- (1) Bolts (बोल्ट्स)
- (2) Upper chain case (ऊपरी चैन कैस)
- (3) Lower chain case (निचला चैन कैस)

3. Inspect the sprocket teeth for possible wear or damage. Replace if necessary.

Damaged sprocket Teeth
(क्षतिग्रस्त स्प्राँकेट टीथ)

Replace
(बदलें)

Worn sprocket Teeth
(घिसा हुआ स्प्राँकेट टीथ)

Replace
(बदलें)

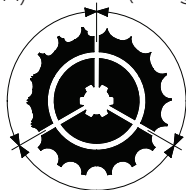

Normal sprocket Teeth
(सामान्य स्प्राँकेट टीथ)

Good
(सही)

If the drive chain or sprockets are excessively worn or damaged, they should be replaced. Never use a new chain with worn sprockets; rapid chain wear will result.

4. Install the chain cases and inspection cap in the reverse order of removal.

Adjustment:

Drive chain slack should be checked and adjusted, if necessary, every 1,000 km (600 miles). When operated at sustained high speeds or under conditions of frequent rapid acceleration, the chain may require more frequent adjustment.

If the drive chain requires adjustment, the procedure is as follows:

1. Place the vehicle on its center stand with the transmission in neutral and the ignition switch off.
2. Loosen the rear axle nut (1)
3. Loosen the drive chain lock nuts (2).
4. Turn both adjusting nuts (3) an equal number of turns until the correct drive chain slack is obtained. Turn the adjusting nuts clockwise to tighten the chain, or counterclockwise to provide more slack.

Align the chain adjuster index marks (4) with the rear edge (5) of the adjusting slots on both sides of the swingarm.

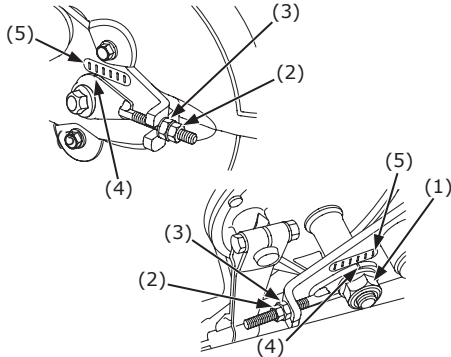

- (1) Rear axle nut (रियर एक्सल नट)
- (2) Drive chain lock nuts (ड्राइव चेन लॉक नट्स)
- (3) Drive chain adjusting nuts (ड्राइव चेन एडजस्टिंग नट्स)
- (4) Index marks (इंडेक्स मार्क्स)
- (5) Rear edge of adjusting slot
(एडजस्टिंग स्लॉट का पिछला किनारा)

If the drive chain slack is excessive when the rear axle is moved to the furthest limit of adjustment, the drive chain is worn and must be replaced.

5. Tighten the rear axle nut to:
54 N·m (5.5 kgf·m , 40 lbf·ft)

If a torque wrench is not used for this installation, see your Honda dealer as soon as possible to verify proper assembly.

6. Tighten the adjusting nuts lightly, then tighten the lock nuts by holding the adjusting nuts with a spanner.
7. Recheck drive chain slack.
8. Rear brake pedal free play is affected when repositioning the rear wheel to adjust drive chain slack. Check rear brake pedal free play and adjust as necessary (page 16.).

Lubrication:

Lubricate every 1,000 km (600 miles) or sooner if chain appears dry.

Use any one of the following methods for lubricating drive chain:

- SAE 80 or 90 gear oil.
- Honda recommended chain maintenance spray.

- Molten grease in greasilator (visit your Honda dealer for this service).

Saturate each chain link joint so that the lubricant penetrates between the link plates, pins, bushings, and rollers.

Replacement chain:

LGB 420 BS-116L
OR
DID 420 AD-116RB

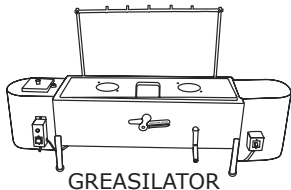
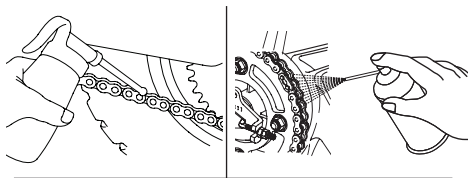

Removal and Cleaning:

When the drive chain becomes dirty, it should be removed and cleaned prior to lubrication.

1. With the engine off, remove the drive chain cases (page 53) and carefully remove the master link retaining clip (1) with a pair of pliers. Do not bend or twist the clip. Remove the master link. Remove the drive chain from the vehicle.

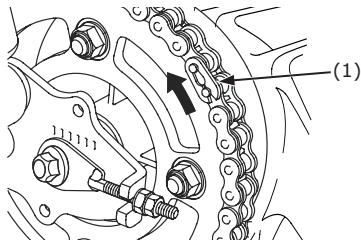

(1) Retaining clip (रिटैनिंग क्लिप)

2. Clean the drive chain in high flash-point solvent and allow it to dry. Inspect the drive chain for possible wear or damage.

Replace any chain that has damaged rollers, loose fitting links, or otherwise appears unserviceable.

Never use petrol or low flash point solvents for cleaning the drive chain. A fire or explosion could result.

3. Inspect the sprocket teeth for possible wear or damage. Replace if necessary. Never use a new drive chain on badly worn sprockets. Both chain and sprockets must be in good condition, or the new replacement chain or sprocket will wear rapidly.
4. Lubricate the drive chain (page 55).
5. Pass the chain over the sprockets and join the ends of the chain with the master link. For ease of assembly, hold the chain ends against adjacent rear sprocket teeth while inserting the master link.
6. The master link is the most critical part affecting the security of the drive chain. Master links are reusable, if they remain in excellent condition, but it is recommended that a new master link retaining clip be installed whenever the drive chain is reassembled.

Install the master link retaining clip so that the closed end of the clip will face the direction of forward wheel rotation.

7. Adjust the drive chain (page 54) and rear brake pedal free play (page 16).
8. Install the drive chain cases (page 54).

FRONT AND REAR SUSPENSION INSPECTION

Refer to the Safety Precautions on page 39.

1. Check the front fork assembly by locking the front brake and pumping the fork up and down vigorously. Suspension action should be smooth and there must be no oil leakage.
2. Swingarm bearings should be checked by pushing hard against the side of the rear wheel while the vehicle is on the center stand. Free play indicates worn bearings.
3. Carefully inspect all front and rear suspension fasteners for tightness.

SIDE STAND

Refer to the Safety Precautions on page 39. Check the side stand spring (1) for damage and loss of tension, and the side stand assembly for freedom of movement.

If the side stand is squeaky or stiff, clean the pivot area and lubricate the pivot bolt with clean engine oil.

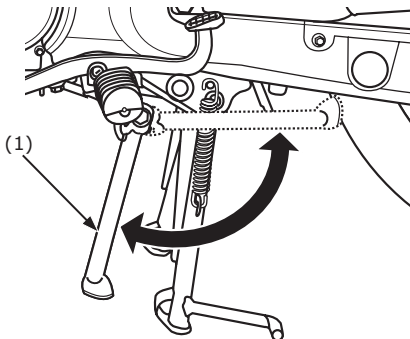

(1) Side stand spring (साइड स्टैन्ड स्प्रिंग)

WHEEL REMOVAL

Refer to the Safety Precautions on page 39.

Front Wheel Removal (for Disc & CBS)

1. Place the vehicle on its center stand.
2. Raise the front wheel off the ground by placing a support block under the engine.
3. Remove the front axle nut (1).
4. Remove the front axle shaft (2) and the wheel.

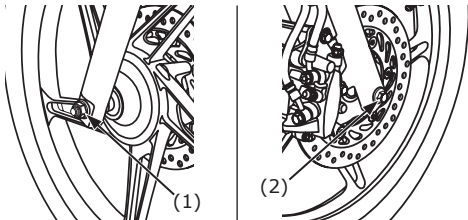

(1) Front axle nut (फ्रंट एक्सल नट)

(2) Front axle shaft (फ्रंट एक्सल शाफ्ट)

Do not depress the brake lever when the wheel is off the vehicle. The caliper piston will

be forced out of the cylinder with subsequent loss of brake fluid. If this occurs, servicing of the brake system will be necessary. Visit your Honda dealer for this service.

Installation Notes:

- Reverse the removal procedure.
- Position the wheel between the fork legs and insert the front axle from the right side, through the right fork leg and wheel hub.
- Tighten the front axle nut to the specified torque.

Front axle nut torque:

54 N·m (5.5 kgf·m , 40 lbf·ft)

- After installing the wheel, apply the brake several times and then check if the wheel rotates freely. Recheck the wheel if the brake drags or if the wheel does not rotate freely.

If a torque wrench was not used for installation, see your Honda dealer as soon as possible to verify proper assembly. Improper assembly may lead to loss of braking capacity.

Front Wheel Removal (for Drum brake)

1. Place the vehicle on its center stand.
2. Raise the front wheel off the ground by placing a support block under the engine.
3. Remove the front brake adjusting nut (1) and remove the front brake cable (2) from the brake arm (3).
4. Remove the front axle nut (4).
5. Remove the front axle shaft (5) and the wheel.

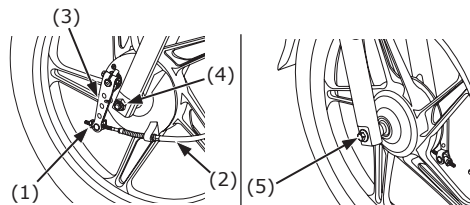

- (1) Brake adjusting nut (ब्रेक एडजस्टिंग नट)
- (2) Front brake cable (फ्रंट ब्रेक केबल)
- (3) Brake arm (ब्रेक आर्म)
- (4) Front axle nut (फ्रंट एक्सल नट)
- (5) Front axle shaft (फ्रंट एक्सल शाफ्ट)

Installation Notes:

- Position the wheel between the fork legs and insert the front axle from the right side, through the right fork leg and wheel hub.
- Make sure that the tang (8) on the left front fork leg is located in the slot (9) in the brake panel.

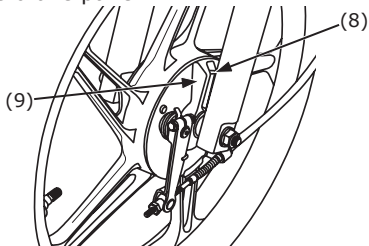

(8) Tang (टैंग)

(9) Slot (स्लोट)

- Tighten the front axle nut to the specified torque.

Front axle nut torque:

54 N·m (5.5 kgf·m , 40 lbf·ft)

- Adjust the brake (page 14-15).
- After installing the wheel, apply the brake several times and then check if the wheel rotates freely. Recheck the wheel if the brake drags or if the wheel does not rotate freely.

If a torque wrench was not used for installation, see your Honda dealer as soon as possible to verify proper assembly.

Improper assembly may lead to loss of braking capacity.

Rear Wheel Removal

1. Place the vehicle on its center stand.
2. Remove the drive chain cases (page 53).
3. Remove the rear brake adjusting nut (1). Disconnect the brake rod (2) from the brake arm (3).
4. Disconnect the brake stopper arm (4) from the brake panel by removing the cotter pin (5) stopper arm nut (6) washer and rubber grommet.

- Loosen the drive chain lock nut (7) and drive chain adjusting nut (8).
- Remove the rear axle nut (9).

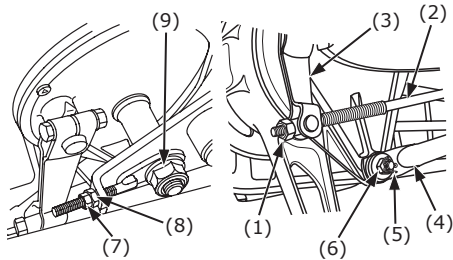

- Brake adjusting nut (ब्रेक एडजस्टिंग नट)
- Brake rod (ब्रेक रोड)
- Brake arm (ब्रेक आर्म)
- Brake stopper arm (ब्रेक स्टोपर आर्म)
- Cotter pin (कोटर पिन)
- Stopper arm nut (स्टोपर आर्म नट)
- Drive chain lock nut (ड्राइव चैन लॉक नट)
- Drive chain adjusting nut (ड्राइव चैन एडजस्टिंग नट)
- Rear axle nut (रियर एक्सल नट)

- Remove the drive chain (10) from the driven sprocket by pushing the rear wheel forward.
- Remove the rear axle shaft (11), side collar (12) and rear wheel from the swingarm.

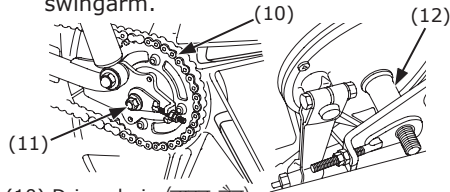

- Drive chain (ड्राइव चैन)
- Rear axle shaft (रियर एक्सल शाफ्ट)
- Side collar (साइड कॉलर)

Installation Notes:

- Reverse the removal procedure.
- Tighten the rear axle nut and brake stopper arm nut to specified torque:

Rear axle nut torque:

54 N·m (5.5 kgf·m , 40 lbf·ft)

Brake stopper arm nut torque:

22 N·m (2.2 kgf·m , 16 lbf·ft)

- Adjust the brake (page 16-17) and drive chain (page 54).
- After installing the wheel, apply the brake several times and then check if the wheel rotates freely. Recheck the wheel if the brake drags or if the wheel does not rotate freely.
- Always replace used cotter pins with new ones.

If a torque wrench was not used for installation, see your Honda dealer as soon as possible to verify proper assembly. Improper assembly may lead to loss of braking capacity.

BRAKE PAD WEAR (for Disc & CBS)

Refer to the Safety Precautions on page 39.

Brake pad wear depends upon the severity of usage, the type of riding, and road conditions. (Generally, the pads will wear faster on wet and dirty roads.)

Inspect the pads at each regular maintenance interval (page 42).

Check the wear indicator grooves (1) in each pad.

If either pad is worn to the bottom of the grooves, replace both pads as a set. Visit your Honda dealer for this service.

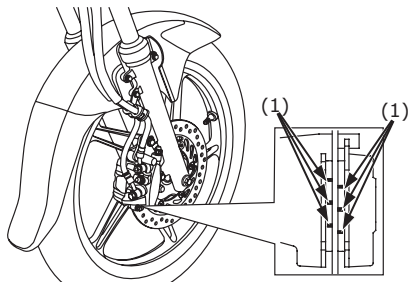

(1) Wear indicator grooves (घिसावट संकेतक गूँस)

BRAKE SHOE WEAR

Refer to the Safety Precautions on page 39.

(For Drum Brake)

The front and rear brakes are equipped with brake wear indicators.

(For Disc & CBS)

The rear brake is equipped with a brake wear indicator.

When the brake is applied, an arrow (1) attached to the brake arm (2) moves toward a reference mark (3) on the brake panel (4). If the arrow aligns with the reference mark on full application of the brake, the brake shoes must be replaced.

Visit your Honda dealer for this service.

(Front Brake) for drum brake

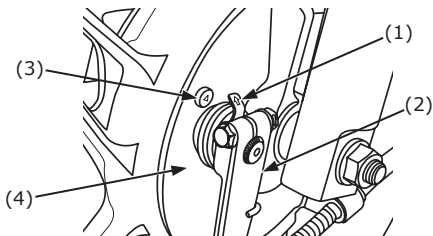

(Rear Brake)

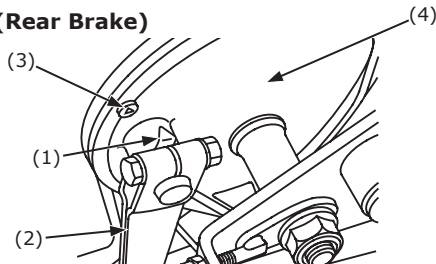

- (1) Arrow mark (तीर का निशान)
- (2) Brake arm (ब्रेक आर्म)
- (3) Reference mark (संदर्भ मार्क)
- (4) Brake panel (ब्रेक पैनल)

BATTERY

Refer to the safety precautions on page 39. It is not necessary to check the battery electrolyte level or add distilled water as the battery is a maintenance-free (sealed) type. If your battery seems weak and/or is leaking electrolyte (causing hard starting or other electrical troubles), contact your Honda dealer or battery manufacturer.

NOTICE

Your battery is maintenance-free type and can be permanently damaged if the cap strip is removed.



This symbol on the battery means that this product must not be treated as household waste.

NOTICE

Battery contains lead, which is a hazardous material and if improperly disposed, can be harmful to the environment and human health.

Always return the used maintenance-free battery to the Honda dealer.

⚠ WARNING

The battery gives off explosive hydrogen gas during normal operation.

A spark or flame can cause the battery to explode with enough force to kill or seriously hurt you.

Wear protective clothing and a face shield or have a skilled mechanic do the battery maintenance.

Keep children away from the battery.

Removal

1. Make sure the ignition switch is OFF.
2. Remove the left side cover (page 29).
3. Remove the bolt (1) and open the battery holder (2).
4. Disconnect the negative (-) terminal lead (3) from the battery, first.
5. Disconnect the positive (+) terminal lead (4) and remove the positive terminal clip (5) from the battery holder.

6. Pull out the battery (6) from the battery box.

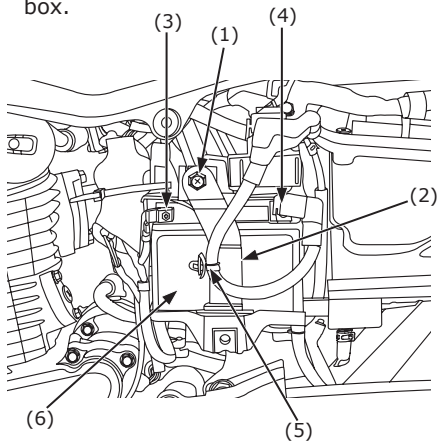

- (1) Bolt (बोल्ट)
(2) Battery holder (बैटरी होल्डर)
(3) Negative (-) terminal lead (नेगेटिव(-)टर्मिनल लीड)
(4) Positive (+) terminal lead (पॉजिटिव (+)टर्मिनल लीड)
(5) Clip (क्लिप)
(6) Battery (बैटरी)

Installation

1. Reinstall in the reverse order of removal. Be sure to connect the positive (+) terminal first, then the negative (-) terminal.
2. Install and route the positive terminal cable by installing the clip in to the battery holder as shown in the illustration
3. Check all bolts and other fasteners are secure.
4. Apply petroleum jelly on both terminals after connecting.

FUSE REPLACEMENT

Refer to the Safety Precautions on page 39.

When frequent fuse failure occurs, it usually indicates a short circuit or an overload in the electrical system. See your Honda dealer for repair.

NOTICE

Never use a fuse with a different rating from that specified. Serious damage to the electrical system or a fire may result, causing a dangerous loss of lights or engine power.

Turn the ignition switch OFF before checking or replacing the fuses to prevent an accidental short-circuit.

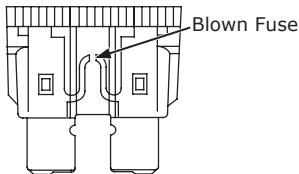

Fuse Box:

The fuse box (1) is located behind the left side cover.

The specified fuse is: 15A

1. Remove the left side cover (page 29).
2. Open fuse box cover (2).
3. Pull out the old fuse and install a new fuse. The spare fuse (3) is attached in the fuse box.
4. Close the fuse box cover and install the left side cover & seat.

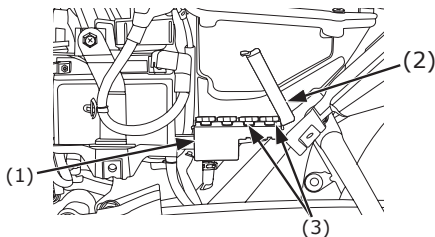

- (1) Fuse box (फ्यूज बॉक्स)
- (2) Fuse box cover (फ्यूज बॉक्स कवर)
- (3) Spare fuse (स्पेयर फ्यूज)

MAIN FUSE:

The main fuse (1) is located behind the left side cover.

The specified fuse is : 20A

1. Remove the left side cover (page 29).
2. Disconnect the wire connector (2) of the starter magnetic switch (3).

3. Pull out the fuse. If the fuse is blown, install a new fuse.

The spare main fuse (4) is located with starter magnetic switch.

4. Reconnect the wire connector and install the left side cover and the seat.

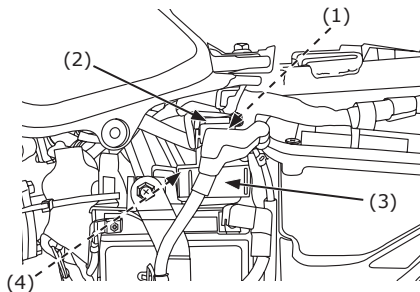

- (1) Main fuse (मेन फ्यूज)
- (2) Wire connector (वायर कनेक्टर)
- (3) Starter magnetic switch (स्टार्टर मैग्नेटिक स्विच)
- (4) Spare Main fuse (अतिरिक्त मेन फ्यूज)

STOPLIGHT SWITCH ADJUSTMENT

Refer to the Safety Precautions on page 39. Check the operation of the stoplight switch (1) at the right side behind the engine from time to time.

Adjustment is done by turning the adjusting nut (2). Turn the nut in the direction (A) if the switch operates too late and in direction (B) if the switch operates too soon.

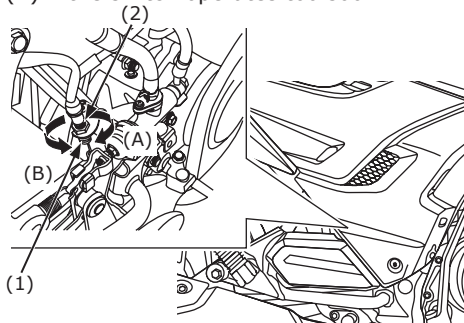

- (1) Stoplight switch (स्टॉपलाइट स्विच)
(2) Adjusting nut (एडजस्टिंग नट)

BULB REPLACEMENT

Refer to the Safety Precautions on page 39. The light bulb becomes very hot while the light is ON, and remains hot for a while after it is turned OFF. Be sure to let it cool down before servicing.

Do not put finger prints on the headlight bulb, as they may create hot spots on the bulb and cause it to break.

Wear clean gloves while replacing the bulb. If you touch the bulb with your bare hands, clean it with a cloth moistened with alcohol to prevent its early failure.

- Be sure to turn the ignition switch OFF when replacing the bulb.
- Do not use bulbs other than those specified.
- After installing a new bulb, check that the light operates properly.

Position Light Bulb

1. Remove the front cowl (1) by removing the screws (2).
2. Disconnect the headlight connector (3).
3. Pull out the position light bulb (4) out of the head light unit and remove the bulb from its holder.
4. Install a new bulb in reverse order of removal

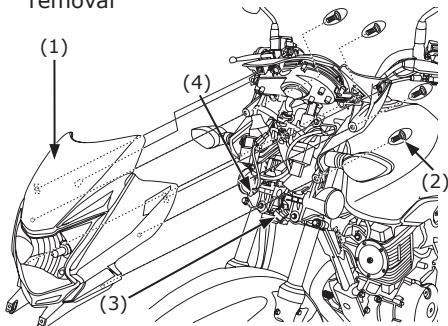

- (1) Front cowl (फ्रंट काउल)
(2) Screws (स्क़ूस)
(3) Headlight connector (हेड लाइट कनेक्टर)
(4) Position Light Bulb (पोज़िशन लाइट बल्ब)

Headlight Bulb

1. Remove the front cowl (Page 69).
2. Disconnect the headlight connector.
3. Remove the dust cover (1).
4. Remove the headlight bulb (2) while pressing the pin (3).
5. Install a new bulb in the reverse order of removal.
 - Install the seat rubber with its "Arrow" mark (4) facing up.

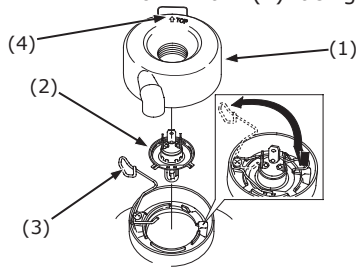

- (1) Dust cover (डस्ट कवर)
(2) Headlight bulb (हेडलाइट बल्ब)
(3) Pin (पिन)
(4) "Arrow" mark (तीर का निशान)

Stop/Tail Light Bulb

1. Remove the stop/tail light lens (1) by removing the screw (2).
2. Slightly press the bulb (3), turn it counterclockwise and remove.
3. Install a new bulb in the reverse order of removal.

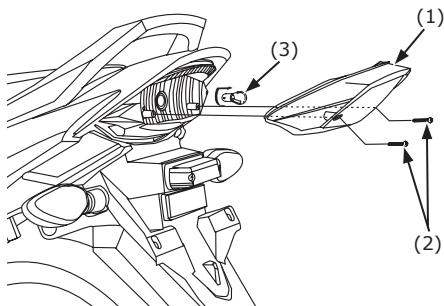

- (1) Stop/tail light lens (स्टॉप टेल लाइट लेंस)
(2) Screw (स्क़्रू)
(3) Bulb (बल्ब)

Licence Plate Light Bulb

1. Remove the Licence plate light cover (1) by removing the screws (2).
2. Slightly pull the bulb (3).
3. Install a new bulb in the reverse order of removal.

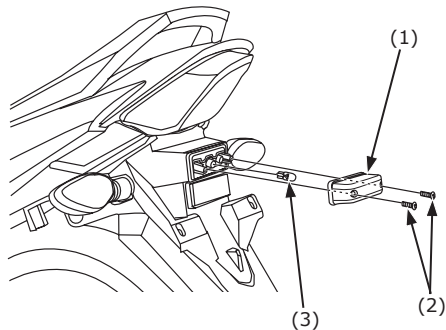

- (1) Licence plate light cover (लाइसेंस प्लेट लाइट कवर)
(2) Screws (स्क़्रूस)
(3) Bulb (बल्ब)

Front/Rear Turn Signal Bulb

1. Remove the turn signal lens (1) by removing the screw (2).
2. Slightly press the bulb (3) and turn it counterclockwise.
3. Install a new bulb in the reverse order of removal.

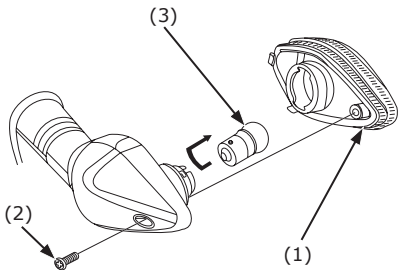

- (1) Turn signal lens (टर्न सिग्नल लेंस)
(2) Screw (स्क़्रू)
(3) Bulb (बल्ब)

CLEANING

Clean your vehicle regularly to protect the surface finishes and inspect for damage, wear, and oil or brake fluid leakage.

Avoid cleaning products that are not specifically designed for vehicle or automobile surfaces.

They may contain harsh detergents or chemical solvents that could damage the metal, paint, and plastic on your vehicle.

If your vehicle is still warm from recent operation, give the engine and exhaust system time to cool off.

We recommend avoiding the use of high pressure water spray (typical in coin operated car washes).

NOTICE

High pressure water (or air) can damage certain parts of the vehicle.

Washing the Vehicle

1. Rinse the vehicle thoroughly with cool water to remove loose dirt.

2. Clean the vehicle with a sponge or soft cloth using cool water.
Avoid directing water to muffler outlets and electrical parts.

3. Clean the plastic parts using a cloth or sponge dampened with a solution of mild detergent and water. Rub the soiled area gently rinsing it frequently with fresh water.

Take care to keep brake fluid or chemical solvents off the vehicle.

They will damage the plastic and painted surfaces.

The inside of the headlight lens may be clouded immediately after washing the vehicle. Moisture condensation inside the headlight lens will disappear gradually by lighting the headlight in high beam. Run the engine while keeping the headlight on.

4. After cleaning, rinse the vehicle thoroughly with plenty of clean water. Strong detergent residue can corrode alloy parts.

5. Dry the vehicle, start the engine, and let it run for several minutes.

6. Test the brakes before riding the vehicle. Several applications may be necessary to restore normal braking performance.

7. Lubricate the drive chain immediately after washing and drying the vehicle.

Braking efficiency may be temporarily impaired immediately after washing the vehicle.

Anticipate longer stopping distance to avoid a possible accident.

Finishing Touches

After washing your vehicle, consider using a commercially-available spray cleaner/polish or quality liquid or paste wax to finish the job. Use only a non abrasive polish or wax made specifically for vehicles or automobiles. Apply the polish or wax according to the instructions on the container.

If a surface on your vehicle is chipped or scratched, your Honda dealer has touch up paint to match your vehicle's color. Be sure to use your vehicle's color code (page 43) when you buy touch-up paint.

Removing Road Salt

The salt contained in the road surface freezing prevention medicine which a road was sprayed with in winter, and the seawater becomes the cause which rust occurs in.

Wash your vehicle by the following point after it runs through such a place.

1. Clean the vehicle using cool water (page 71).

Do not use warm water.

This worsens the effect of the salt.

2. Dry the vehicle and the surface of the metal is protected with the wax.

STORAGE GUIDE

Extended storage, such as for winter, requires that you take certain steps to reduce the effects of deterioration from non-use of the vehicle. In addition, necessary repairs should be made BEFORE storing the vehicle; otherwise, these repairs may be forgotten by the time the vehicle is removed from storage.

STORAGE

1. Change the engine oil.
2. Empty the fuel tank into an approved petrol container using a commercially available hand siphon or an equivalent method. Spray the inside of the tank with an aerosol rust-inhibiting oil.

Reinstall the fuel fill cap on the tank.

If storage will last more than one month, carburetor draining is very important, to assure proper performance after storage.

WARNING

Petrol is highly flammable and explosive. You can be burned or seriously injured when handling fuel.

- Stop the engine and keep heat, sparks, and flame away.
- Refuel only outdoors.
- Wipe up spills immediately.

3. To prevent rusting in the cylinder, perform the following:
 - Remove the spark plug cap from the spark plug. Using tape or string, secure the cap to any convenient plastic body part so that it is positioned away from the spark plug.
 - Remove the spark plug from the engine and store it in a safe place. Do not connect the spark plug to the spark plug cap.
 - Pour a table spoon (15-20 cm³) of clean engine oil into the cylinder and cover the spark plug hole with a piece of cloth.
 - Crank the engine several times to distribute the oil.
 - Reinstall the spark plug and spark plug cap.
4. Remove the battery. Store in an area protected from freezing temperatures and direct sunlight.
5. Wash and dry the vehicle. Wax all painted surfaces. Coat chrome with rust inhibiting oil.
6. Lubricate the drive chain (page 55).
7. Inflate the tyres to their recommended pressures. Place the vehicle on blocks to raise both tyres off the ground.
8. Cover the vehicle (don't use plastic or other coated materials) and store in an unheated area, free of dampness with a minimum of daily temperature variation. Do not store the vehicle in direct sunlight.

REMOVAL FROM STORAGE

1. Uncover and clean the vehicle.
2. Change the engine oil if more than 4 months have passed since the start of storage.
3. Check the battery voltage and charge the battery as required. Install the battery.
4. Drain any excess aerosol rust-inhibiting oil from the fuel tank. Fill the fuel tank with fresh petrol.
5. Perform all Pre-ride Inspection checks (page 32).

Test ride the vehicle at low speeds in a safe riding area away from traffic.

SPECIFICATIONS

DIMENSIONS

Overall length -----	2007 mm (79.0 in)
Overall width -----	762 mm (29.9 in)
Overall height -----	1,085 mm (42.7 in)
Wheel base -----	1266 mm (49.8 in)

WEIGHT

Dry weight	Drum -----	111 kg (244.7 lbs)
	Disc -----	111 kg (244.7 lbs)
	CBS -----	115 kg (253.5 lbs)

CAPACITIES

Engine oil	After draining -----	0.9 L (0.9 US qt, 0.8 Imp qt)
	After disassembly ---	1.0 L (1.1 US qt, 0.9 Imp qt)
Fuel tank -----		10.5 L (2.77 US gal, 2.31 Imp gal)
Fuel tank reserve -----		1.9 L (0.50 US gal, 0.42 Imp gal)
Passenger capacity -----		Rider and one pillion rider
Maximum weight capacity -----		170 Kg (375 lbs)

ENGINE

Bore and stroke -----		52.4 x 57.8 mm (2.06x2.28 in)
Compression ratio -----		9.2:1
Displacement -----		124.7 cm ³ (7.61 cu-in)
Spark plug -----		
Standard -----		CPR7EA-9 (NGK)/ UR6DC (BOSCH)
Spark plug gap -----		0.8-0.9 mm (0.03-0.04 in)
Idle speed -----		1,400 ± 100 min ⁻¹ (rpm)
Valve clearance (Cold)	Intake -----	0.08 mm (0.003 in)
	Exhaust -----	0.12 mm (0.005 in)

CHASSIS AND SUSPENSION

Caster -----	26°00'
Trail length -----	91 mm (3.58 in)
Tyre size, front -----	80/100-18 M/C 47P
Tyre size, rear -----	80/100-18 M/C 54P

POWER TRANSMISSION

Primary reduction -----	3.350
Gear ratio, 1st -----	3.416
2nd -----	1.944
3rd -----	1.350
4th -----	1.120
5th -----	0.958
Final reduction -----	2.928

ELECTRICAL

Battery -----	12V-3Ah (M.F) ETZ4
Generator -----	0.14 kW/5,000 min ⁻¹ (rpm)

LIGHTS

Head light -----	12V-35/35W
Position light -----	12V-5W
Stop/tail light -----	12V-21/5W
Licence plate light -----	12V-5W
Turn signal light -----	12V-10W x 4
Instrument lights -----	LED
Speedometer lamp -----	LED
Neutral, Turn signal & High beam indicator --	LED

FUSE

Main fuse -----	20A
Sub fuse -----	15A & 10A

Warranty Policy

Honda Vehicle & Scooter India (Pvt.) Ltd. (HMSI) gives the following warranty in respect of vehicle **"CB125 Shine SP"** manufactured by them.

Proper care and precaution has been taken to ensure the best quality in respect of the material and workmanship in manufacturing **"CB125 Shine SP"**.

HMSI would repair or replace at its discretion, those part(s) found to have manufacturing defects during examination. This repair or replacement of part(s) would be done free of charge at their authorised workshop, within a warranty period of 24 months from the date of sale or until the vehicle has covered 32000 kms, whichever comes first.

Warranty claims in respect of proprietary parts like tyres and battery are warranted by their respective manufacturers and should be claimed on them directly by customer.

NOTE: Battery Warranty is applicable from 21 months from Date Of Charging at manufacturer or 18 Months from the Date Of Sale or 20000 Kms whichever is earlier.

In all such cases the decision of the respective manufacturer will be final and binding.

HMSI shall not be liable in any manner to replace them though their dealers will give full assistance in preferring such claims on their manufacturers.

HMSI undertake no liability in the matter of consequential loss or damage caused due to the failure of the parts. Delay, if any, at the repairing workshop in carrying out repair to vehicle shall not be a ground for extending the warranty period nor shall it give any right to the customer for claiming any compensation for damages.

HMSI reserves the right either to repair or replace the defective part.

Where a defective part can be replaced by part/s of alternative brand/s, which are normally used by HMSI in the course of manufacturing, HMSI reserves the right to carry out the replacement by a part or parts of any such alternative brands.

Valid in India only

This warranty and any claim arising there from is subject to Gurgaon jurisdiction only.

No claim for exchange or repair can be consider unless the customer:

- a. Ensures that immediately upon discovery of the defect, he approaches any nearest authorised dealer of HMSI with the concerned vehicle and enables him to remove and dispatch the part/parts attributing to manufacturing defect to the company.
 - b. Produces Owner's Manual in original, to enable that dealer to verify the details. It must be expressly understood that claims forwarded directly to us by the Owner/customer will not be entertained at all and such defective part/parts thus forwarded by them will lie at our factory at their own risk, and this warranty shall not be enforceable.
4. Fasteners and clips which needs replacement during maintenance/service will not be covered under warranty.
 5. If there is any damage to the painted surface due to industrial pollution or other extraneous factors.
 6. Any damage resulting from unavoidable natural disaster i.e fire collision, earthquake, flood etc.
 7. Any damage caused by exposure of the product to soot and smoke, chemical agents, bird-droppings, sea water, sea breeze, or other environmental phenomenon.
 8. If there is any damage caused due to usage of improper oil/grease, non genuine parts.

Further this warranty is not applicable to:

1. Any "CB125 Shine SP" on which any free and paid services has not been carried out, as per schedule given in Owner's Manual.
2. Normal maintenance operations like valve adjustment, cleaning of fuel system, engine tune-up or such other adjustments.
3. HMSI does not warrant normal wear and tear items like brake pad, brake shoes, Clutch Disc, Chain, Chain Sprocket, Wheel Rim (in

case of misalignment and bent), Bushes, Fasteners, Shims, Washers and Electrical Items like Bulbs(LEDs are covered under warranty), Rubber and Plastic Components like Grommets, O-Rings, Bellows as well as Packings, Gaskets, Oil Seals and Consumable like Fuel Filter, Air Cleaner Element, Engine Oil, Grease, Suspension Oil and other items as specified by HMSI.

9. For two-wheelers, which have been used for any commercial purposes as taxi etc.
10. For maintenance repairs required due to misuse while driving or due to adulteration of oil, petrol or due to bad road conditions.
11. Recommended fuel quality not used.
12. Parts of the vehicle that have been subjected to misuse, accident, negligent treatment or which have been used in conjunction with parts and an equipment not manufactured or recommended for use by HMSI if in the sole judgment of HMSI, such use prematurely affects the performance and reliability of the vehicle.
13. Parts of the vehicle that have been altered or modified or replaced in unauthorised manner, and which in the sole judgment of HMSI affect its performance and reliability.
14. The vehicle that has not been serviced by HMSI authorised dealer as per the service schedule or which have not been operated or maintained in accordance with instructions mentioned in the Owner's Manual.
15. The vehicles used for any competition or race and/or for attempting to set up any kind of record HMSI reserves the right to make any

changes in design or to add any improvement on the vehicle at any time without incurring any obligations to install the same on a vehicle previously supplied and sold. Also the conditions of this warranty are subject to alteration without any notice.

This warranty is entirely written warranty given by HMSI for "**CB125 Shine SP**" and no other person, including the dealer or its or his agent or employee is authorised to extend or enlarge this warranty.

This warranty is given in lieu of and excludes every condition or warranty whether statutory or otherwise not herein expressly set out.

EMISSION WARRANTY

Subject to other terms of the warranty policy and other conditions and obligations laid down hereunder, the manufacturer certifies that the components liable to affect the emission of the gaseous pollutants in the vehicle in normal use despite the use to which it may be subjected, comply with provisions of rule 115(2) of the Central Motor Vehicle Rules, 1989 and further warrants that if on examination by a service center duly authorized by the manufacturer, the vehicle is discovered to be failing to meet the emission standard as specified in the said rule,

Valid in India only

the authorized service center shall take such corrective measures as may be necessary and shall at its sole discretion replace free of charge such components of emission control system as are specified in schedule.

A. Conditions

1. This warranty will be in addition to and run parallel to the product warranty given by the manufacturer and will apply to components as mentioned later. This warranty is applicable in Delhi, Mumbai, Kolkata and Chennai with effective from 1st July 2001. Other places when included will be covered under warranty accordingly.
2. The period of the vehicle's emission warranty will be determined starting from the date of the vehicle sale. The period of time and kilometers that are covered under the provisions of warranty may vary but should not be less than the minimum warranty period based on the vehicle category.

For a two-wheeler the emission warranty period is 30,000 kms or 3 years whichever is earlier.

3. Warranty claim for the components under Emission warranty as per annexure-II will be admitted, for a prima facie examination, in

the event of failure of the vehicle to meet the emission standard as specified in sub-rule (2) of Rule No 115 of the Central Motor vehicle Rules.

4. The warranty claim will be accepted only after the examinations carried out by Authorized Service Centers leads to a firm conclusion that none of the original settings have been tampered with and that the components as mentioned in ANNEXURE - II has/have a manufacturing defect, and/or, that the vehicle is unable to meet the in-use emission standard, in spite of the vehicle being maintained and used in accordance with the instructions in the owner's manual.
5. The methods of examination to determine the warrantable condition of the components will be at the sole discretion of manufacturers and or their Authorized service centers and results of such examination will be final and binding. If, on examination, a warrantable condition is not established, the manufacturers will have to charge all, or part, of the cost of such examination.
6. In case of a vehicle in which the components covered under Emission warranty, the manufacturer will replace, at Authorized centers free of charge, the components which

- are covered as mentioned in Annexure-II, but the consumables as mentioned in Owner's Manual shall be charged as per actuals.
7. In case of a vehicle in which the components covered under Emission warranty or the associated parts are not independently replaceable on account of their being integral parts of a complete assembly, the manufacturer will have the sole discretion to replace either the entire assembly or by using some of the parts of the system through suitable repairs or modifications.
 8. Any consequential repairs or replacement of parts which may be found necessary to establish compliance to in-use emission standards, in addition to replacement of the parts covered under emission warranty, will not be made free of cost unless such parts are also found to be in a warrantable condition within the scope and limit of the product warranty. The consumables shall be charged as per actuals during such repairs or replacement of parts.
 9. All the parts removed for replacement under warranty will be the property of the manufacturer.
10. The manufacturer will not be responsible for the cost of transportation of the vehicle to the nearest Authorized Service center or any loss due to non-availability of the vehicle during the period of lodging of a warranty claim and examination by the manufacturer and repairs.
 11. The manufacturer will not be responsible for any penalties that may be charged by statutory authorities on account of failure to comply with the in use emission standards.
 12. Emission warranty will be applicable irrespective of the change of ownership of the vehicle provided all the conditions as laid down in this document are met from the date of original sale of the vehicle.
 13. The emission warranty will be applicable only if:
 - a. Observes all important instructions and any other precautions listed in the Owner's Manual for use of the vehicle.
 - b. Under all circumstances uses lubricants and fuel as recommended by manufacturer.

Valid in India only

- c. Regularly obtains and carries out maintenance in accordance with the manufacturers guidelines and enters the details in the Logbook.
 - d. Immediately approaches the nearest authorized service center upon discovery of failure to comply with the in use emission standards in spite of having maintained and used the vehicle in accordance with the instructions in the Owner's Manual and having carried out such repairs and adjustments as may be required with a view to establish such compliance.
 - e. Produces the 'Pollution Under Control' certificate valid for the period immediately preceding the test during which the failure is discovered, the test having been carried out either for obtaining a new certificate, or pursuant upon being directed by an officer as referred to in sub-rule(2) of Rule 116 of the Central Motor Vehicle Rules.
 - f. Produces the Owner's Manual and Log book for verification details.
 - g. Produces receipts covering maintenance of the vehicle as specified in the Owner's Manual from the date of original purchase of the vehicle.
 - h. Produces valid certificate of insurance and RTO registration.
14. Conditions under which warranty is not applicable:
- A valid 'Pollution Under Control' certificate as described in customer obligation D(6) above is not produced.
- A vehicle which is not serviced by Authorized service center as per the service schedule described in the maintenance chart given in the Owner's Manual.
- A vehicle, which has been subjected to abnormal use, abuse, neglect and improper maintenance or has met with an accident. Use of replacement parts not specified and approved by the manufacturer.
- A vehicle, or parts thereof, which has been altered, tampered with or modified or replaced in an unauthorized manner.

A vehicle on which the odometer is not functioning or the odometer has been changed/tampered with so that the actual mileage cannot be readily determined.

A vehicle which has been used for competitions, races, rallies or for the purpose of establishing records

Examination by the manufacturers or his Authorized Service Centers of the vehicle shows that any of the conditions stipulated in the Owner's Manual with regard to use and maintenance have been violated.

A vehicle, which has been run on, adulterated fuel, leaded fuel or lubricant or fuel/lubricants other than those specified by the manufacturer in the Owner's Manual with regard to use and maintenance have been violated.

SCOPE AND LIMITS

1. This emission warranty is in addition to product warranty and shall run parallel to the product warranty for the vehicle as per the scope and limit described in the Owner's Manual and all conditions described there in will apply in addition to those exclusively stipulated in this warranty.

2. The emission warranty covers only compliance with the emission standard as specified in the sub rule (2) of rule 115 of CMVR. It does not cover any other performance of these parts or routine test and consequent maintenance or adjustments to establish compliance to the in use emission standard as applicable to the state, in which the vehicle is registered and is in use.

The parts, which are covered under emission warranty, are carburetor and internal parts, intake manifold, distributor and internal parts, ignition coil, muffler etc.

NOTE: The emission warranty is applicable only when a customer enters into emission warranty contract.